

THIS DRAWING IS UNPUBLISHED. RELEASED FOR PUBLICATION
 © COPYRIGHT - By - ALL RIGHTS RESERVED.

LOC		DIST		REVISIONS			
P	LTR	DESCRIPTION		DATE	DWN	APVD	
GP	00	Y		REVISED PER ECO-14-013983	15JUN2015	AP	DG

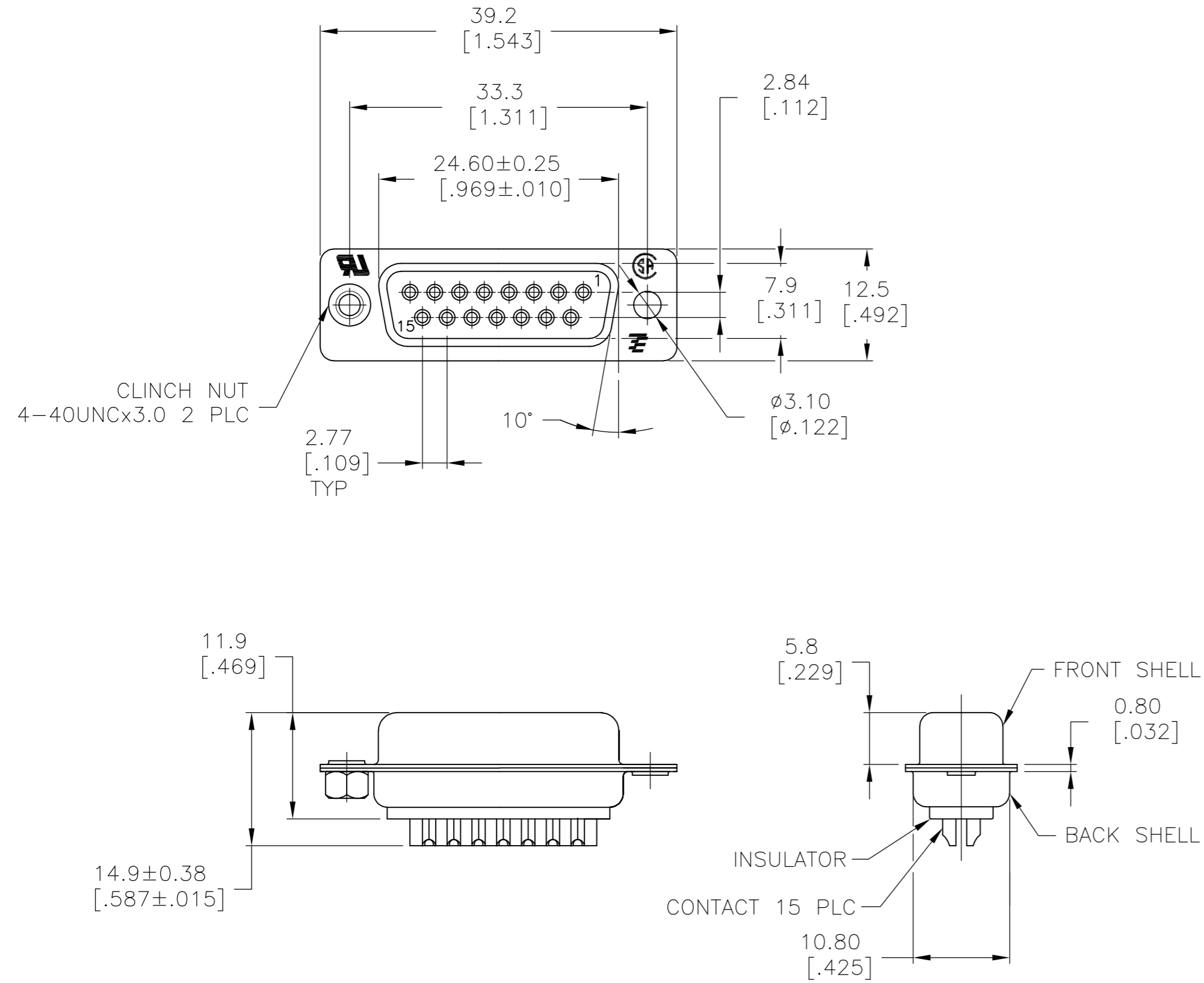

- 1 MATERIAL:
 BACK INSULATOR: PBT, 30 %GF, UL94V-0, BLACK COLOR
 FRONT INSULATOR: PBT, 30 %GF, UL94V-0, BLACK COLOR
 CONTACT: BRASS
 BACK SHELL: STEEL
 CLINCH NUTS: BRASS
 FRONT SHELL: STEEL
- 2 FINISH:
 CONTACT: GOLD PLATING 0.00002[.0000008] MIN ON CONTACT AREA 0.00229 [.000090] MIN TIN-LEAD PLATING ALL OVER 0.00127[.000050] MIN NICKEL
- 3 CONTACT: GOLD PLATING 0.00076[.000030] MIN ON CONTACT AREA 0.00229 [.000090] MIN TIN-LEAD PLATING ALL OVER 0.00127[.000050] MIN NICKEL
- 4 SHELL: BRIGHT TIN 0.0241[.000095] MIN FULL SHELL
- 5 SHELL: BLUE ZINC: 0.00508[.000200] - 0.00762[.000300] OVER ENTIRE SHELL
- 6 CONTACT: GOLD PLATING 0.00002[.0000008] MIN ON CONTACT AREA 0.00229 [.000090] MIN HOT DIPPED TIN-COPPER PLATING ALL OVER 0.00127[.000050] MIN NICKEL.
- 7 CLINCH NUTS: NICKEL PLATING .00305-.00508[.000120-.000200]
- 8 SPECIFICATION
 ELECTRICAL CHARACTERISTICS: CURRENT RATING: 3 AMPERES
 DIELECTRIC WITHSTANDING VOLTAGE: AC 1000V r.m.s
 INSULATION RESISTANCE: 5000 MEGOHMS MINIMUM AT DC 500V
 CONTACT RESISTANCE: 10 MILLIOHMS MAXIMUM.
- 9 ROHS 2002/95/EC COMPLIANT
- 10 RECEPTACLE ASSEMBLY MATES WITH ANY 15 POSITION PLUG IN AMPLIMITE SERIES
- 11 SOLDER CUP WILL ACCOMMODATE 20 MAX AWG WIRE.
- 12 CONTACT: GOLD PLATING 0.00076[.000030] MIN ON CONTACT AREA 0.00229[.000090] MIN HOT DIPPED TIN-COPPER ALL OVER 0.00127[.000050] MIN NICKEL PLATING

△	OBSOLETE	STANDARD	NO	△	△	5-747909-4
△	OBSOLETE	STANDARD	YES	△	△	5-747909-7
		STANDARD	NO	△	△	5-747909-5
		STANDARD	NO	△	△	5-747909-2
	SUPERSEDED TO 5-747909-2	STANDARD	NO	△	△	747909-8
	SUPERSEDED TO 5-747909-7	STANDARD	YES	△	△	747909-7
	SUPERSEDED TO 5-747909-5	STANDARD	NO	△	△	747909-5
	SUPERSEDED TO 5-747909-4	STANDARD	NO	△	△	747909-4
	SUPERSEDED TO 5-747909-2	STANDARD	NO	△	△	747909-2

THIS DRAWING IS A CONTROLLED DOCUMENT. DIMENSIONING AND TOLERANCING PER ASME Y14.5M-2009		DWN M.BINNER 03MAR03	TE Connectivity			
DIMENSIONS: mm [INCHES]		CHK R.BENDORF 05MAR03	RECEPTACLE ASSEMBLY, SOLDER CUP, SIZE 2, 15 POSN, HD-20, AMPLIMITE			
TOLERANCES UNLESS OTHERWISE SPECIFIED:		APVD R.BENDORF 05MAR03	NAME	SIZE	CAGE CODE	DRAWING NO
0 PLC	± -	PRODUCT SPEC		A2	00779	C=747909
1 PLC	± 0.25	APPLICATION SPEC				
2 PLC	± 0.13					
3 PLC	± 0.05					
4 PLC	± -					
ANGLES	± 4°					
MATERIAL	FINISH	WEIGHT	SCALE	SHEET	1 OF 1	REV
1	SEE TABLE	-	2:1	1	1	Y
CUSTOMER DRAWING						

747909

A