



DC COMPONENTS CO., LTD.

RECTIFIER SPECIALISTS

S3A
THRU
S3M

TECHNICAL SPECIFICATIONS OF SURFACE MOUNT SILICON RECTIFIER

VOLTAGE RANGE 50 to 1000 Volts

CURRENT 3.0 Ampere

FEATURES

- * Ideal for surface mounted applications
- * Low leakage current
- * Glass passivated junction

MECHANICAL DATA

- * Case: Molded plastic
- * Epoxy: UL 94V-0 rate flame retardant
- * Terminals: Solder plated, solderable per MIL-STD-750, Method 2026
- * Polarity: As marked
- * Mounting position: Any
- * Weight: 0.093 gram

MAXIMUM RATINGS AND ELECTRICAL CHARACTERISTICS

Ratings at 25 °C ambient temperature unless otherwise specified.
Single phase, half wave, 60 Hz, resistive or inductive load.
For capacitive load, derate current by 20%.



SMC(DO-214AB)

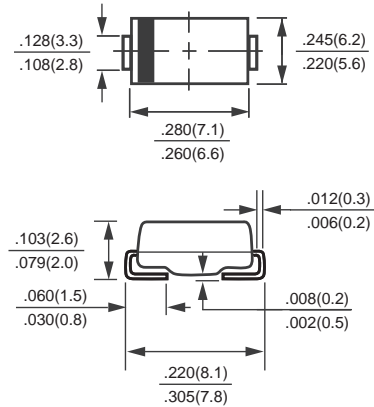

Dimensions in inches and (millimeters)

	SYMBOL	S3A	S3B	S3D	S3G	S3J	S3K	S3M	UNITS
Maximum Recurrent Peak Reverse Voltage	V _{RRM}	50	100	200	400	600	800	1000	Volts
Maximum RMS Voltage	V _{RMS}	35	70	140	280	420	560	700	Volts
Maximum DC Blocking Voltage	V _{DC}	50	100	200	400	600	800	1000	Volts
Maximum Average Forward Rectified Current at T _A = 75°C	I _O	3.0							Amps
Peak Forward Surge Current I _{FM} (surge): 8.3 ms single half sine-wave superimposed on rated load (JEDEC method)	I _{FSM}	100							Amps
Maximum Forward Voltage at 1.0A DC	V _F	1.2							Volts
Maximum DC Reverse Current at Rated DC Blocking Voltage	I _R	@ T _A = 25°C							uAmps
		@ T _A = 125°C							
Maximum Reverse Recovery Time (Note 3)	t _{rr}	2.5							uSec
Typical Thermal Resistance (Note 2)	R _{θJL}	10							°C/W
Typical Junction Capacitance (Note 1)	C _J	60							pF
Operating and Storage Temperature Range	T _J , T _{STG}	-65 to + 175							°C

- NOTES : 1. Measured at 1.0 MHz and applied reverse voltage of 4.0 Volts
 2. Thermal Resistance (Junction to Ambient), .04x0.4 in² (10x10mm²) copper pads to each terminal.
 3. Test Conditions: I_F=0.5A, I_R=1.0A, I_{RR}=0.25A.

RATING AND CHARACTERISTIC CURVES (S3A THRU S3M)

FIG. 1 - TYPICAL FORWARD CURRENT DERATING CURVE

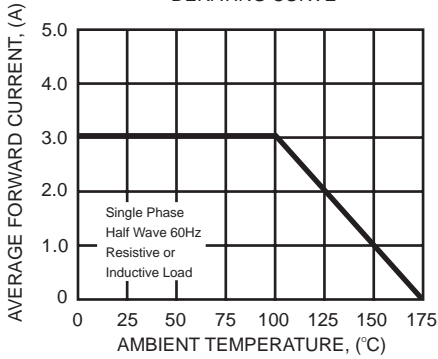

FIG. 2 - MAXIMUM NON-REPETITIVE FOREARD SURGE CURRENT

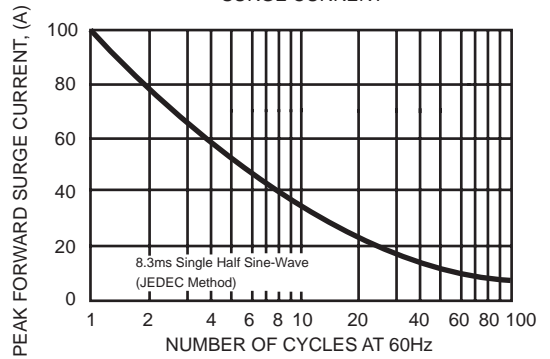

FIG. 3 - TYPICAL INSTANTANEOUS FORWARD CHARACTERISTICS

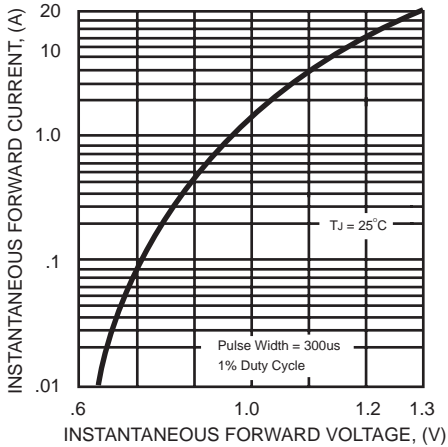

FIG. 4 - TYPICAL REVERSE CHARACTERISTICS

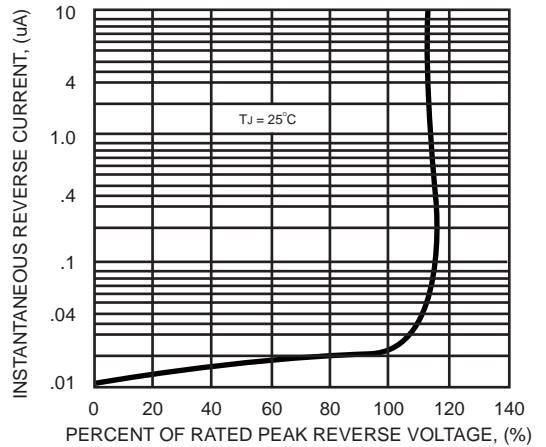
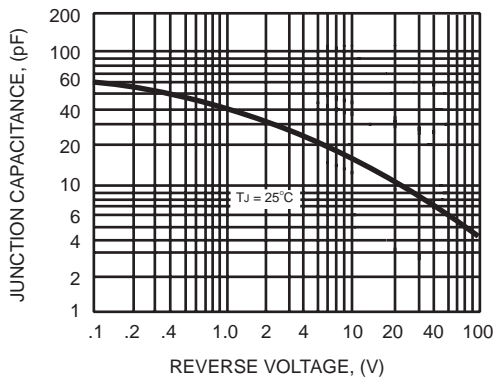

FIG. 5 - TYPICAL JUNCTION CAPACITANCE



DC COMPONENTS CO., LTD.