

CNY171, CNY172, CNY173, CNY174, CNY17F1, CNY17F2, CNY17F3, CNY17F4, MOC8101, MOC8102, MOC8103, MOC8104, MOC8105, MOC8106, MOC8107, MOC8108 Phototransistor Optocouplers

Features

- UL recognized (File # E90700)
- VDE recognized
 - Add option V for white package (e.g., CNY17F2VM)
 - File #102497
 - Add option '300' for black package (e.g., CNY17F2300)
 - File #94766
- Current transfer ratio in select groups
- High BV_{CEO} —70V minimum (CNY17X/M, CNY17FX/M, MOC8106/7/8)
- Closely matched current transfer ratio (CTR) minimizes unit-to-unit variation.
- Very low coupled capacitance along with no chip to pin 6 base connection for minimum noise susceptibility (CNY17FX/M, MOC810X)

Applications

- Power supply regulators
- Digital logic inputs
- Microprocessor inputs
- Appliance sensor systems
- Industrial controls

Description

The CNY17, CNY17F and MOC810X devices consist of a Gallium Arsenide IRED coupled with an NPN phototransistor in a dual in-line package.

White Package (-M Suffix)

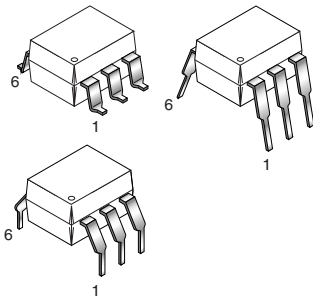

Black Package (No -M Suffix)

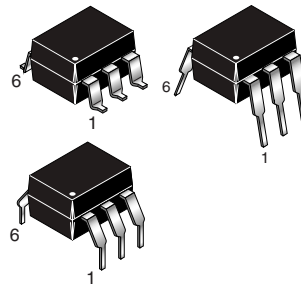

Schematic

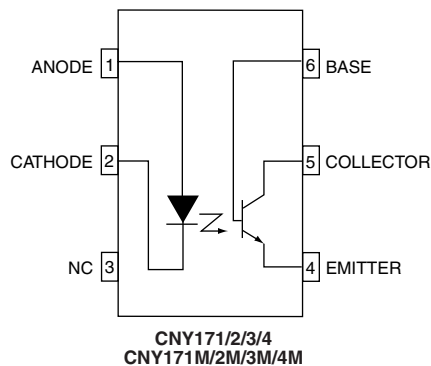
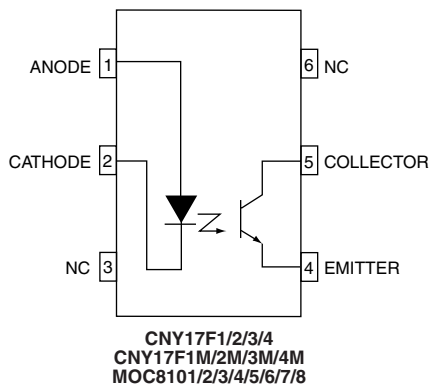

Absolute Maximum Ratings

Symbol	Parameters	Device	Value	Units
TOTAL DEVICE				
T _{STG}	Storage Temperature	M	-40 to +150	°C
		non M	-55 to +150	
T _{OPR}	Operating Temperature	M	-40 to +100	°C
		non M	-55 to +100	
T _{SOL}	Lead Solder Temperature	All	260 for 10 sec	°C
P _D	Total Device Power Dissipation @ 25°C (LED plus detector)	M	250	mW
		non M	250	
	Derate Linearly From 25°C	M	2.94	mW/°C
		non M	3.30	
EMITTER				
I _F	Continuous Forward Current	M	60	mA
		non M	100	
V _R	Reverse Voltage	All	6	V
I _F (pk)	Forward Current - Peak (1 μs pulse, 300 pps)	M	1.5	A
		non M	1.0	
P _D	LED Power Dissipation 25°C Ambient	M	120	mW
		non M	150	
	Derate Linearly From 25°C	M	1.41	mW/°C
		non M	1.8	
DETECTOR				
I _C	Continuous Collector Current	All	50	mA
V _{CEO}	Collector-Emitter Voltage	CNY17X/M, CNY17FX/M, MOC8106/7/8	70	V
		MOC8101/2/3/4/5	30	V
V _{ECO}	Emitter Collector Voltage	All	7	V
P _D	Detector Power Dissipation @ 25°C	M	150	mW
		non M	150	
	Derate Linearly from 25°C	M	1.76	mW/°C
		non M	2.0	

Electrical Characteristics (T_A = 25°C Unless otherwise specified.)⁽¹⁾

Individual Component Characteristics

Symbol	Parameters	Test Conditions	Device	Min.	Typ.	Max.	Units
EMITTER							
V _F	Input Forward Voltage	I _F = 60mA	CNY17FX/M CNY17X/M	1.0	1.35	1.65	V
		I _F = 10mA	MOC810X	1.0	1.15	1.50	
C _J	Capacitance	V _F = 0 V, f = 1.0MHz	All		18		pF
I _R	Reverse Leakage Current	V _R = 6 V	All		0.001	10	μA
DETECTOR							
BV _{CEO}	Breakdown Voltage Collector to Emitter	I _C = 1.0mA, I _F = 0	MOC8101/2/3/4/5	30	100		V
			MOC8106/7/8 CNY17F1/2/3/4/M CNY171/2/3/4/M	70	100		
BV _{CBO}	Collector to Base	I _C = 10μA, I _F = 0	CNY171/2/3/4/M	70	120		
BV _{ECO}	Emitter to Collector	I _E = 100μA, I _F = 0	All	7	10		
I _{CEO}	Leakage Current Collector to Emitter	V _{CE} = 10 V, I _F = 0	All		1	50	nA
I _{CBO}	Collector to Base	V _{CB} = 10 V, I _F = 0	CNY171/2/3/4/M			20	nA
C _{CE}	Capacitance Collector to Emitter	V _{CE} = 0, f = 1MHz	All		8		pF
C _{CB}	Collector to Base	V _{CB} = 0, f = 1MHz	CNY171/2/3/4/M		20		pF
C _{EB}	Emitter to Base	V _{EB} = 0, f = 1MHz	CNY171/2/3/4/M		10		pF

Isolation Characteristics

Symbol	Characteristic	Test Conditions	Device	Min.	Typ.**	Max.	Units
V _{ISO}	Input-Output Isolation Voltage	f = 60 Hz, t = 1 min., I _{I-O} ≤ 2μA ⁽⁴⁾	Black Package	5300			Vac(rms)*
		f = 60 Hz, t = 1 sec., I _{I-O} ≤ 2μA ⁽⁴⁾	'M' White Package	7500			Vac(pk)
R _{ISO}	Isolation Resistance	V _{I-O} = 500 VDC ⁽⁴⁾	All	10 ¹¹			Ω
C _{ISO}	Isolation Capacitance	V _{I-O} = 0, f = 1MHz ⁽⁴⁾	Black Package		0.5		pF
			'M' White Package		0.2		

Note:

* 5300 Vac(rms) for 1 minute equates to approximately 9000 Vac (pk) for 1 second

** Typical values at T_A = 25°C

Transfer Characteristics ($T_A = 25^\circ\text{C}$ Unless otherwise specified.)⁽¹⁾

Symbol	DC Characteristics		Test Conditions	Min.	Typ.	Max.	Units
COUPLED							
(CTR) ⁽²⁾	Output Collector Current	MOC8101	$I_F = 10\text{mA}, V_{CE} = 10\text{V}$	50		80	%
		MOC8102		73		117	
		MOC8103		108		173	
		MOC8104		160		256	
		MOC8105		65		133	
		MOC8106		50		150	
		MOC8107		100		300	
		MOC8108		250		600	
		CNY17F1/1M	$I_F = 10\text{mA}, V_{CE} = 5\text{V}$	40		80	
		CNY17F2/2M		63		125	
		CNY17F3/3M		100		200	
		CNY17F4/4M		160		320	
		CNY171/1M		40		80	
		CNY172/2M		63		125	
		CNY173/3M		100		200	
		CNY174/4M		160		320	
$V_{CE(sat)}$	Collector-Emitter Saturation Voltage	CNY17XM/FXM	$I_C = 2.5\text{mA}, I_F = 10\text{mA}$			0.4	V
		MOC8101/2/3/4/5/6/7/8	$I_C = 500\mu\text{A}, I_F = 5.0\text{mA}$				
		CNY17X/FX	$I_F = 10\text{mA}, I_C = 2.5\text{mA}$			0.3	V

Symbol	AC Characteristics ⁽³⁾		Test Conditions	Min.	Typ.*	Max.	Units
NON-SATURATED SWITCHING TIME							
t_{on}	Turn-On Time	MOC8101/2/3/4/5	$I_C = 2.0\text{mA}, V_{CC} = 10\text{V}, R_L = 100\Omega$		2	20	μs
		MOC8106/7/8					
		CNY17X/FX				10	
t_{off}	Turn-Off Time	MOC8101/2/3/4/5	$I_C = 2.0\text{mA}, V_{CC} = 10\text{V}, R_L = 100\Omega$		3	20	μs
		MOC8106/7/8					
		CNY17X/FX				10	
t_d	Delay Time	CNY17XM/FXM	$I_F = 10\text{mA}, V_{CC} = 5\text{V}, R_L = 75\Omega$			5.6	μs
t_r	Rise Time	All Devices	$I_C = 2.0\text{mA}, V_{CC} = 10\text{V}, R_L = 100\Omega$		1		μs
		CNY17XM/FXM	$I_F = 10\text{mA}, V_{CC} = 5\text{V}, R_L = 75\Omega$			4.0	
t_s	Storage Time	CNY17XM/FXM	$I_F = 10\text{mA}, V_{CC} = 5\text{V}, R_L = 75\Omega$			4.1	μs
t_f	Fall Time	All Devices	$I_C = 2.0\text{mA}, V_{CC} = 10\text{V}, R_L = 100\Omega$		2		μs
		CNY17XM/FXM	$I_F = 10\text{mA}, V_{CC} = 5\text{V}, R_L = 75\Omega$			3.5	

Transfer Characteristics (Continued) ($T_A = 25^\circ\text{C}$ Unless otherwise specified.)⁽¹⁾

Symbol	AC Characteristics ⁽³⁾	Test Conditions	Min.	Typ.	Max.	Units
SATURATED SWITCHING TIMES						
t_{on}	Turn-on Time	CNY171/F1	$I_F = 20\text{mA}$, $V_{CE} = 0.4\text{V}$		5.5	μs
		CNY172/F2 CNY173/F3 CNY174/F4	$I_F = 10\text{mA}$, $V_{CE} = 0.4\text{V}$		8.0	
t_r	Rise Time	CNY171/F1	$I_F = 20\text{mA}$, $V_{CE} = 0.4\text{V}$		4.0	μs
		CNY172/F1 CNY173/F3 CNY174/F4	$I_F = 10\text{mA}$, $V_{CE} = 0.4\text{V}$		6.0	
		CNY171M/F1M	$I_F = 20\text{mA}$, $V_{CC} = 5\text{V}$, $R_L = 1\text{k}\Omega$		4.0	
		CNY172M/3M/4M CNY17F2M/F3M/F4M	$I_F = 10\text{mA}$, $V_{CC} = 5\text{V}$, $R_L = 1\text{k}\Omega$		6.0	
t_d	Delay Time	CNY171M/F1M	$I_F = 20\text{mA}$, $V_{CC} = 5\text{V}$, $R_L = 1\text{k}\Omega$		5.5	μs
		CNY172M/3M/4M CNY17F2M/F3M/F4M	$I_F = 10\text{mA}$, $V_{CC} = 5\text{V}$, $R_L = 1\text{k}\Omega$		8.0	
t_{off}	Turn-off Time	CNY171/F1	$I_F = 20\text{mA}$, $V_{CE} = 0.4\text{V}$		34	μs
		CNY172/F2 CNY173/F3 CNY174/F4	$I_F = 10\text{mA}$, $V_{CE} = 0.4\text{V}$		39	
t_f	Fall Time	CNY171/F1	$I_F = 20\text{mA}$, $V_{CE} = 0.4\text{V}$		20	μs
		CNY172/F2 CNY173/F3 CNY174/F4	$I_F = 10\text{mA}$, $V_{CE} = 0.4\text{V}$		24	
		CNY171M/F1M	$I_F = 20\text{mA}$, $V_{CC} = 5\text{V}$, $R_L = 1\text{k}\Omega$		20.0	μs
		CNY172M/3M/4M CNY17F2M/F3M/F4M	$I_F = 10\text{mA}$, $V_{CC} = 5\text{V}$, $R_L = 1\text{k}\Omega$		24.0	
t_s	Storage Time	CNY171M/F1M	$I_F = 20\text{mA}$, $V_{CC} = 5\text{V}$, $R_L = 1\text{k}\Omega$		34.0	μs
		CNY172M/3M/4M CNY17F2M/F3M/F4M	$I_F = 10\text{mA}$, $V_{CC} = 5\text{V}$, $R_L = 1\text{k}\Omega$		39.0	

** All typicals at $T_A = 25^\circ\text{C}$

Notes:

1. Always design to the specified minimum/maximum electrical limits (where applicable).
2. Current Transfer Ratio (CTR) = $I_C/I_F \times 100\%$.
3. For test circuit setup and waveforms, refer to Figures 20.
4. For this test, Pins 1 and 2 are common, and Pins 4 and 5 are common.

Fig.1 Normalized CTR vs. Forward Current (Black Package)

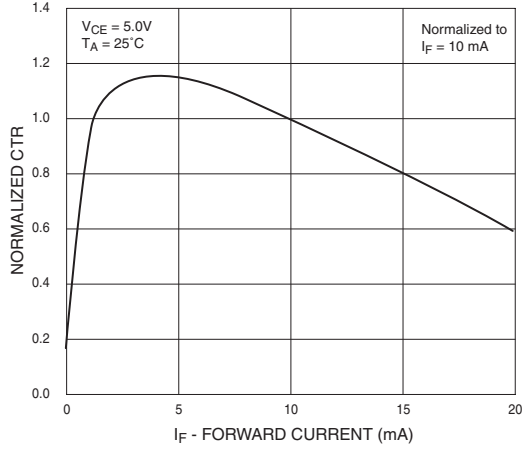

Fig.2 Normalized CTR vs. Forward Current (White Package)

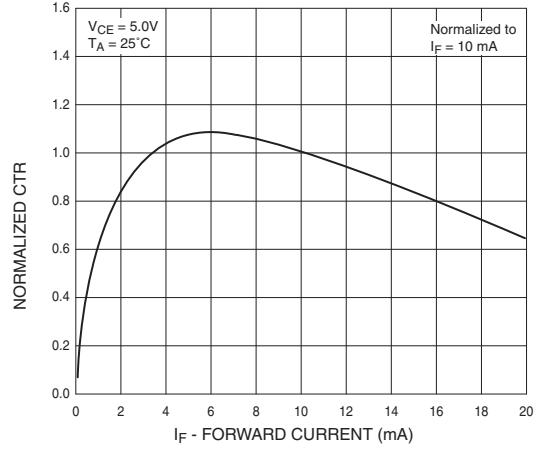

Fig. 3 Normalized CTR vs. Ambient Temperature (Black Package)

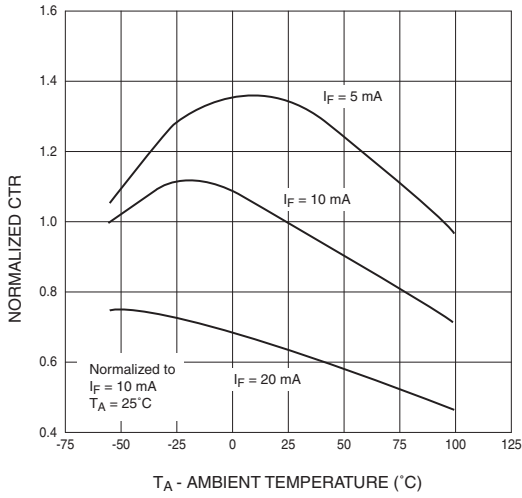

Fig. 4 Normalized CTR vs. Ambient Temperature (White Package)

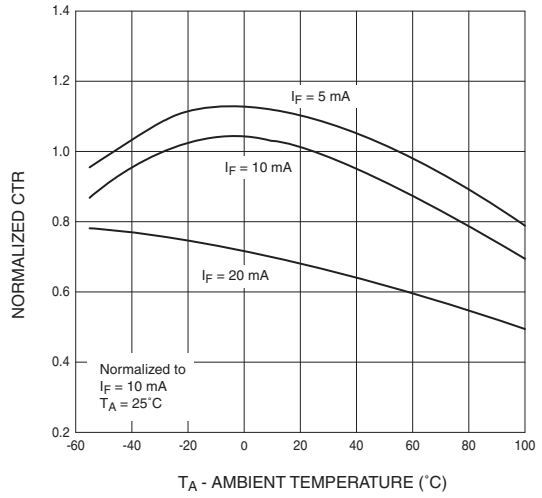

Fig. 5 CTR vs. R_{BE} (Unsaturated) (Black Package)

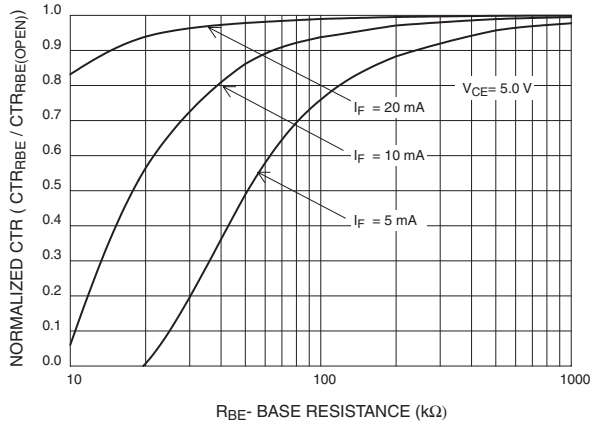
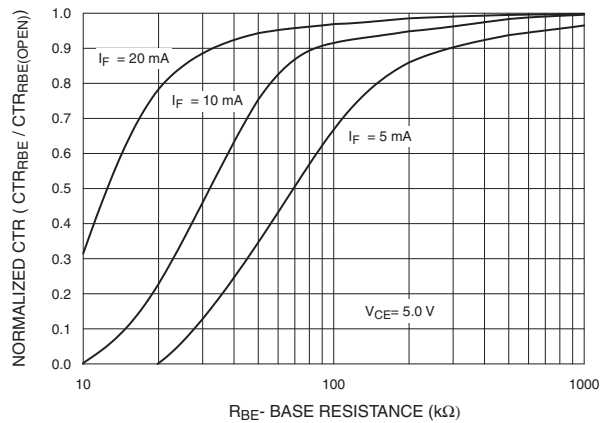
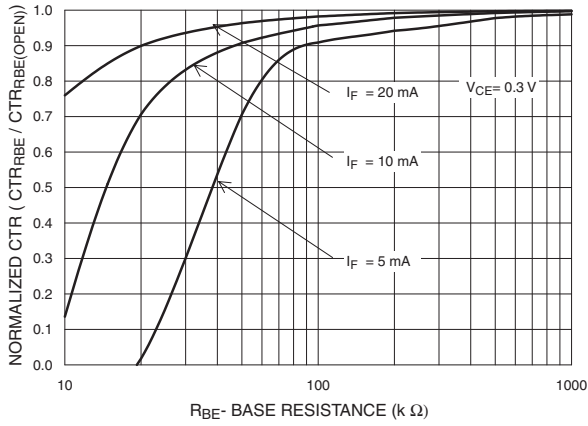

Fig. 6 CTR vs. R_{BE} (Unsaturated) (White Package)



**Fig. 7 CTR vs. R_{BE} (Saturated)
(Black Package)**



**Fig. 8 CTR vs. R_{BE} (Saturated)
(White Package)**

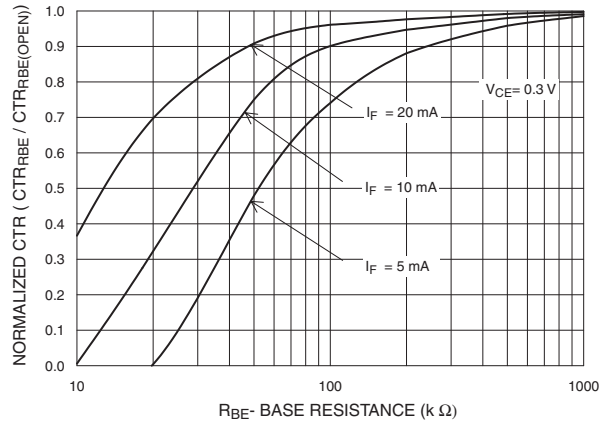

**Fig. 9 Switching Speed vs. Load Resistor
(Black Package)**

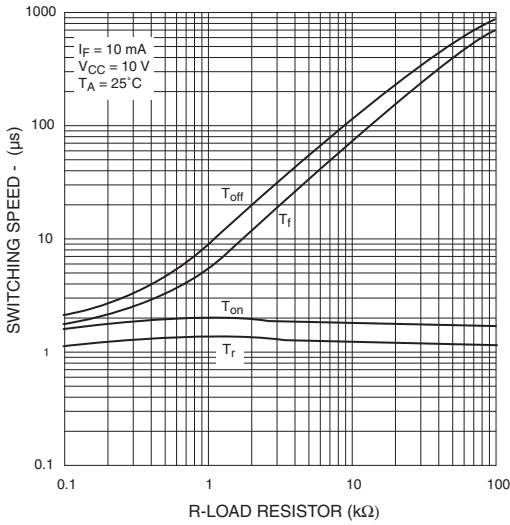

**Fig. 10 Switching Speed vs. Load Resistor
(White Package)**

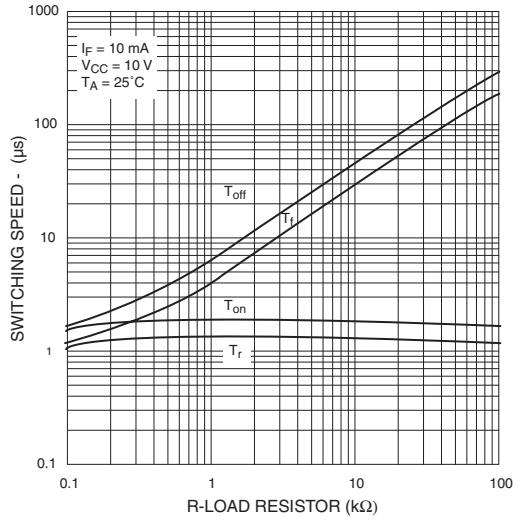

**Fig. 11 Normalized t_{on} vs. R_{BE}
(Black Package)**

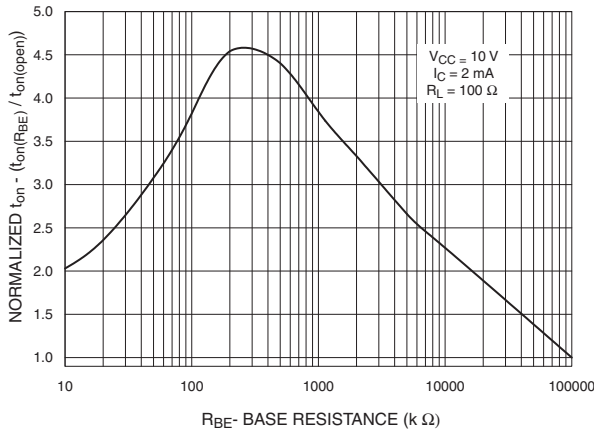

**Fig. 12 Normalized t_{on} vs. R_{BE}
(White Package)**

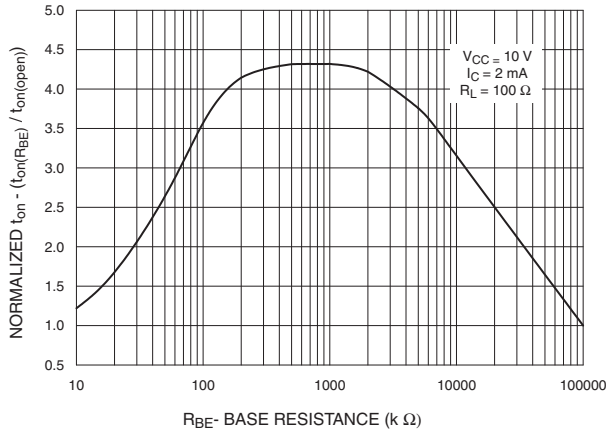

Fig. 13 Normalized t_{off} vs. R_{BE} (Black Package)

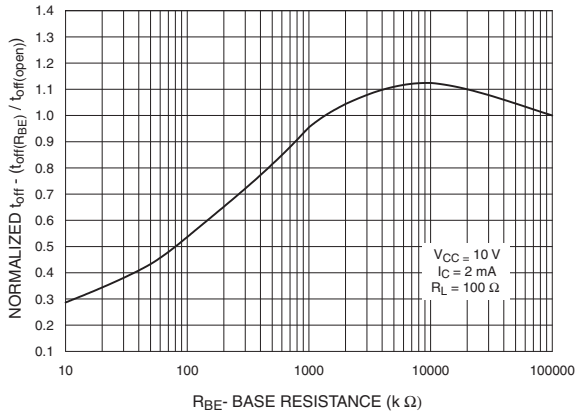

Fig. 14 Normalized t_{off} vs. R_{BE} (White Package)

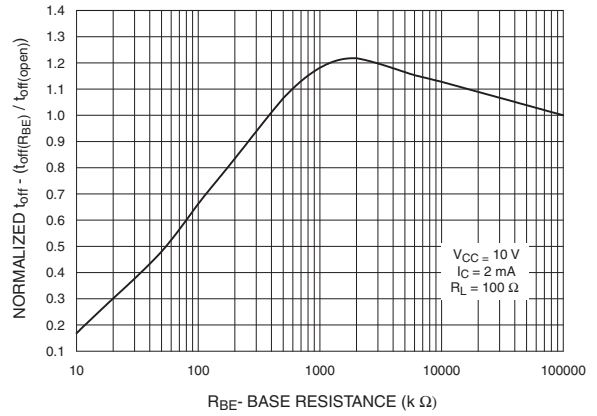

Fig. 15 LED Forward Voltage vs. Forward Current (Black Package)

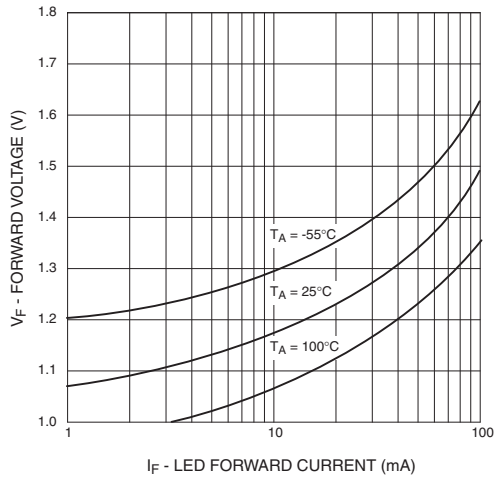

Fig. 16 LED Forward Voltage vs. Forward Current (White Package)

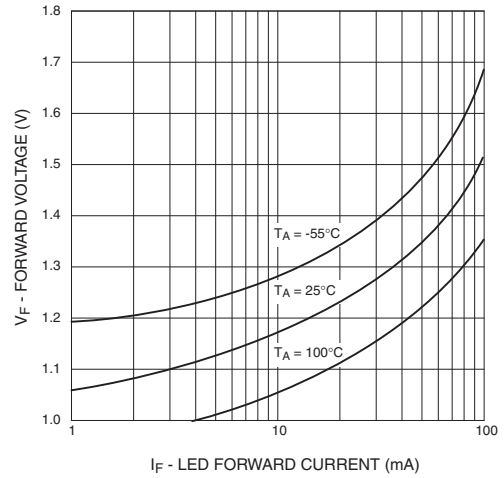

Fig. 17 Collector-Emitter Saturation Voltage vs. Collector Current (Black Package)

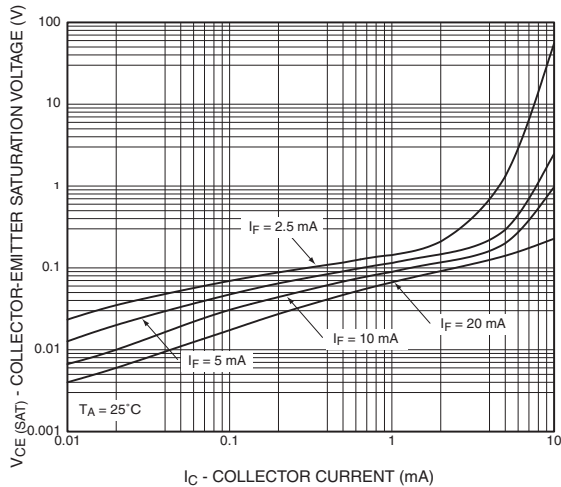

Fig. 18 Collector-Emitter Saturation Voltage vs. Collector Current (White Package)

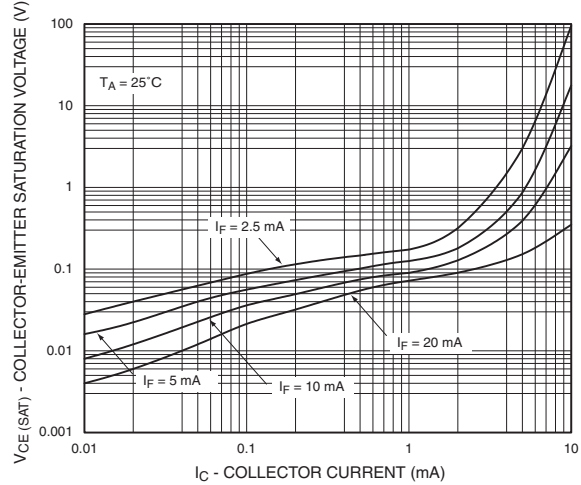

Fig. 19 Dark Current vs. Ambient Temperature (Black Package)

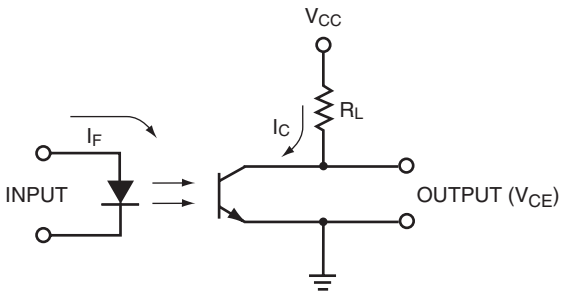
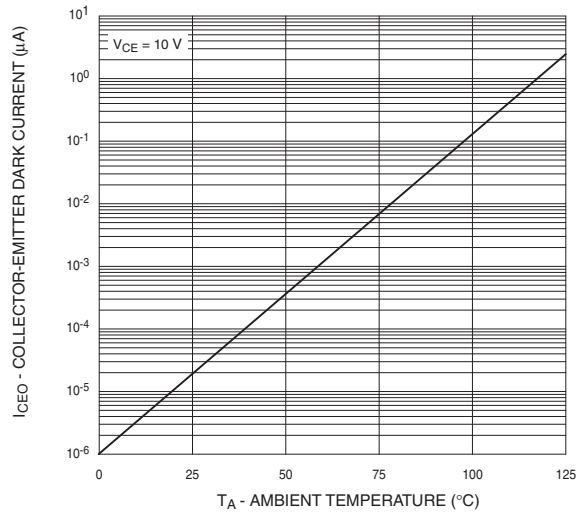

Figure 20. Switching Time Test Circuit

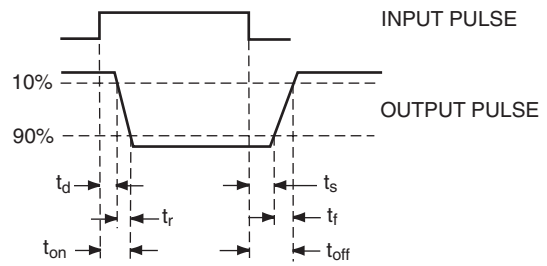
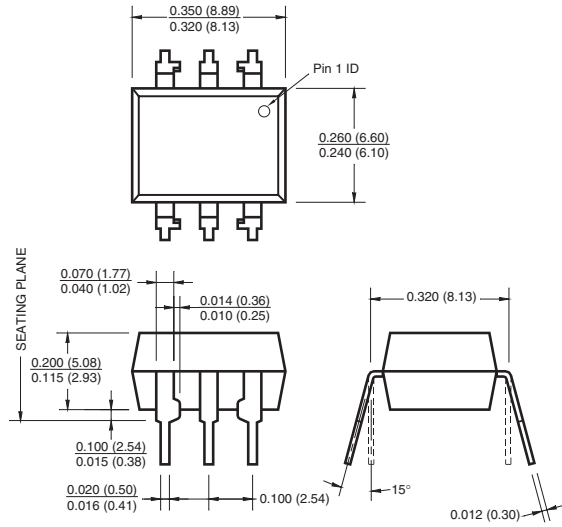

Figure 21. Switching Time Test Circuit

White Package (-M Suffix)

Package Dimensions (Through Hole)



Package Dimensions (Surface Mount)

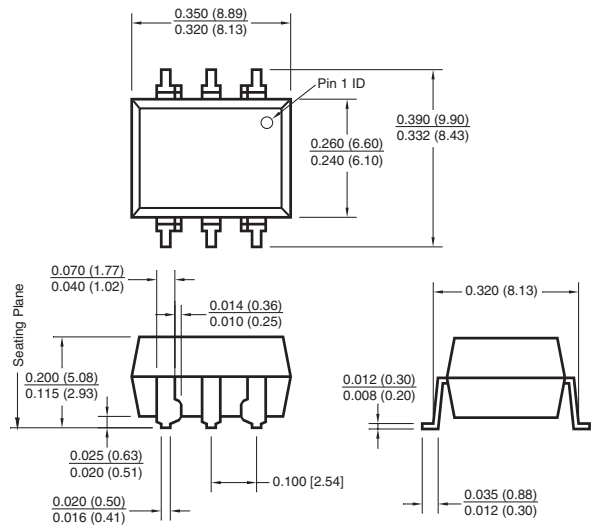

Package Dimensions (0.4" Lead Spacing)

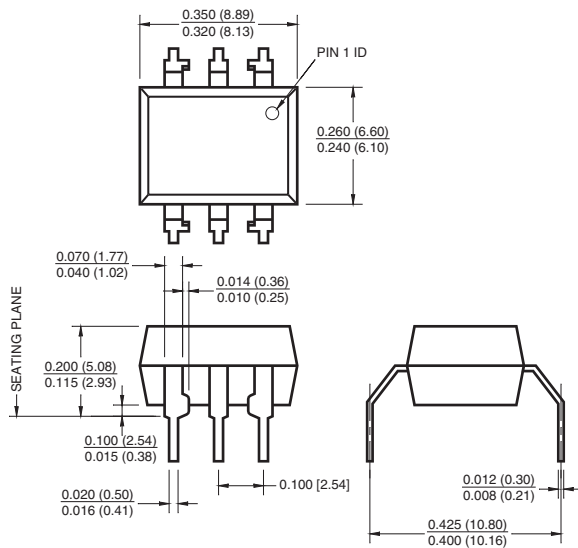

Recommended Pad Layout for Surface Mount Leadform (White Package Only)

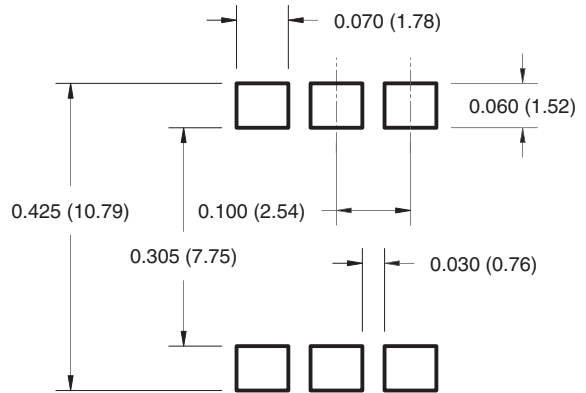

Note:

All dimensions are in inches (millimeters)

Ordering Information

Black Package Part Number Example (No Suffix)	White Package Part Number Example (M Suffix)	Description
CNY171S	CNY171SM	Surface Mount Lead Bend
CNY171SD	CNY171SR2M	Surface Mount; Tape and reel
CNY171W	CNY171TM	0.4" Lead Spacing
CNY171300	CNY171VM	VDE Approved
CNY171300W	CNY171TVM	VDE Approved, 0.4" Lead Spacing
CNY1713S	CNY171SVM	VDE Approved, Surface Mount
CNY1713SD	CNY171SR2VM	VDE Approved, Surface Mount, Tape & Reel

Carrier Tape Specifications (Black Package, No Suffix)

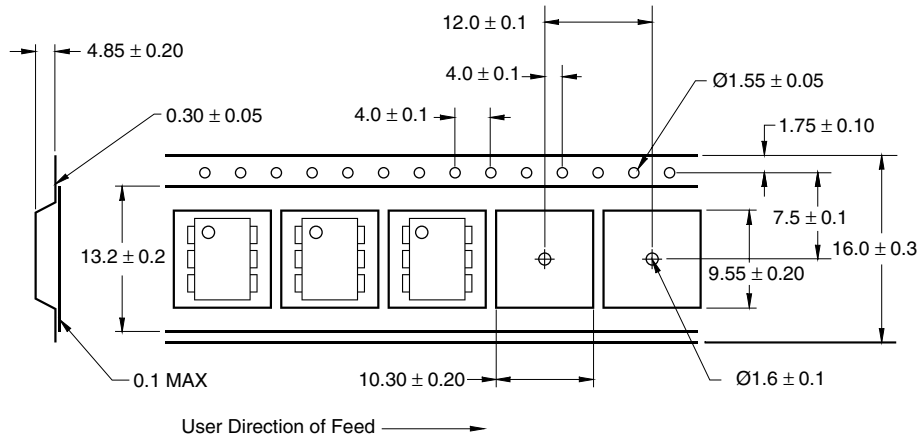

Carrier Tape Specifications (White Package, M Suffix)

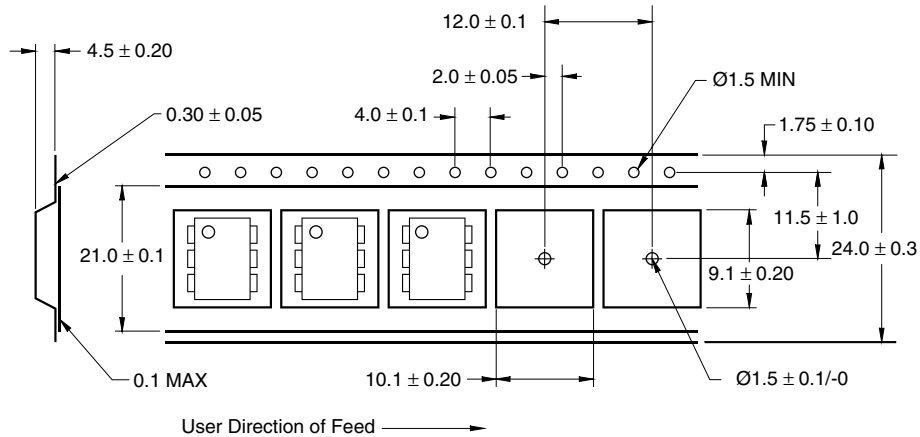

Marking Information (Black package non 'M' suffix)

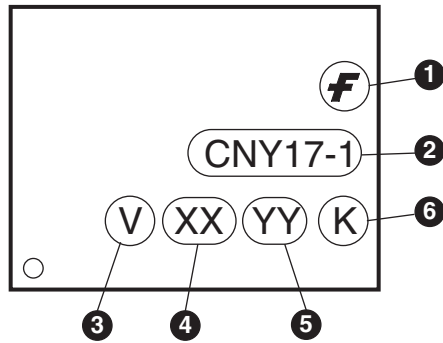

Definitions	
1	Fairchild logo
2	Device number
3	VDE mark (Note: Only appears on parts ordered with VDE option – See order entry table)
4	Two digits year code, e.g., '03'; One digit year code for 'M' version, e.g. '5'
5	Two digit work week ranging from '01' to '53'
6	Assembly package code

Reflow Profile (Black Package, No Suffix)

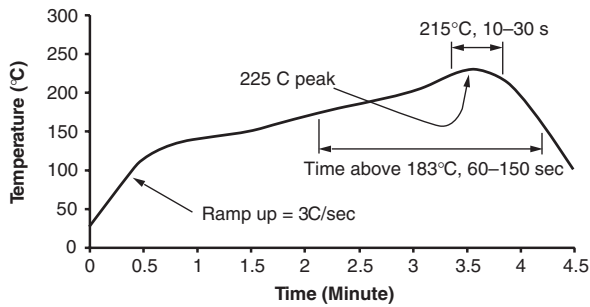

- Peak reflow temperature: 225°C (package surface temperature)
- Time of temperature higher than 183°C for 60–150 seconds
- One time soldering reflow is recommended

Marking Information (White package M suffix)

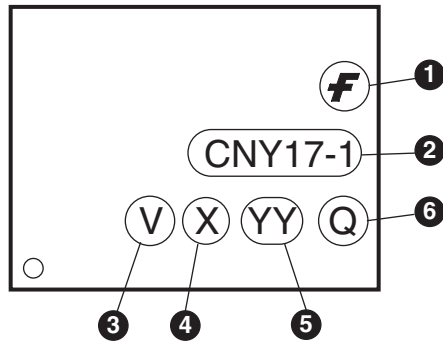

Definitions	
1	Fairchild logo
2	Device number
3	VDE mark (Note: Only appears on parts ordered with VDE option – See order entry table)
4	Single digit year code, e.g. '5'
5	Two digit work week ranging from '01' to '53'
6	Assembly package code

Reflow Profile (White Package, M Suffix)

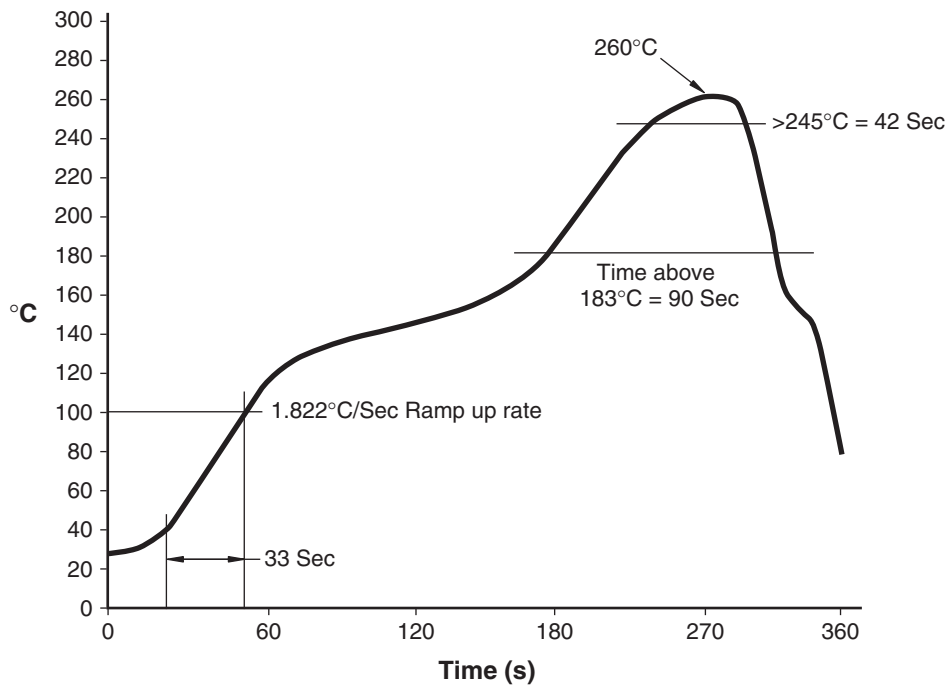

TRADEMARKS

The following are registered and unregistered trademarks Fairchild Semiconductor owns or is authorized to use and is not intended to be an exhaustive list of all such trademarks.

ACEx™	FACT Quiet Series™	OCX™	SILENT SWITCHER®	UniFET™
ActiveArray™	GlobalOptoisolator™	OCXPro™	SMART START™	UltraFET®
Bottomless™	GTO™	OPTOLOGIC®	SPM™	VCX™
Build it Now™	HiSeC™	OPTOPLANAR™	Stealth™	Wire™
CoolFET™	I ² C™	PACMAN™	SuperFET™	
CROSSVOLT™	i-Lo™	POP™	SuperSOT™-3	
DOE™	ImpliedDisconnect™	Power247™	SuperSOT™-6	
EcoSPARK™	IntelliMAX™	PowerEdge™	SuperSOT™-8	
E ² C MOS™	ISOPLANAR™	PowerSaver™	SyncFET™	
EnSigna™	LittleFET™	PowerTrench®	TCM™	
FACT™	MICROCOUPLER™	QFET®	TinyBoost™	
FAST®	MicroFET™	QS™	TinyBuck™	
FASTr™	MicroPak™	QT Optoelectronics™	TinyPWM™	
FPS™	MICROWIRE™	Quiet Series™	TinyPower™	
FRFET™	MSX™	RapidConfigure™	TinyLogic®	
	MSXPro™	RapidConnect™	TINYOPTO™	
Across the board. Around the world.™		μSerDes™	TruTranslation™	
The Power Franchise®		ScalarPump™	UHC™	
Programmable Active Droop™				

DISCLAIMER

FAIRCHILD SEMICONDUCTOR RESERVES THE RIGHT TO MAKE CHANGES WITHOUT FURTHER NOTICE TO ANY PRODUCTS HEREIN TO IMPROVE RELIABILITY, FUNCTION, OR DESIGN. FAIRCHILD DOES NOT ASSUME ANY LIABILITY ARISING OUT OF THE APPLICATION OR USE OF ANY PRODUCT OR CIRCUIT DESCRIBED HEREIN; NEITHER DOES IT CONVEY ANY LICENSE UNDER ITS PATENT RIGHTS, NOR THE RIGHTS OF OTHERS. THESE SPECIFICATIONS DO NOT EXPAND THE TERMS OF FAIRCHILD'S WORLDWIDE TERMS AND CONDITIONS, SPECIFICALLY THE WARRANTY THEREIN, WHICH COVERS THESE PRODUCTS.

LIFE SUPPORT POLICY

FAIRCHILD'S PRODUCTS ARE NOT AUTHORIZED FOR USE AS CRITICAL COMPONENTS IN LIFE SUPPORT DEVICES OR SYSTEMS WITHOUT THE EXPRESS WRITTEN APPROVAL OF FAIRCHILD SEMICONDUCTOR CORPORATION.

As used herein:

- Life support devices or systems are devices or systems which, (a) are intended for surgical implant into the body, or (b) support or sustain life, or (c) whose failure to perform when properly used in accordance with instructions for use provided in the labeling, can be reasonably expected to result in significant injury to the user.
- A critical component is any component of a life support device or system whose failure to perform can be reasonably expected to cause the failure of the life support device or system, or to affect its safety or effectiveness.

PRODUCT STATUS DEFINITIONS

Definition of Terms

Datasheet Identification	Product Status	Definition
Advance Information	Formative or In Design	This datasheet contains the design specifications for product development. Specifications may change in any manner without notice.
Preliminary	First Production	This datasheet contains preliminary data, and supplementary data will be published at a later date. Fairchild Semiconductor reserves the right to make changes at any time without notice to improve design.
No Identification Needed	Full Production	This datasheet contains final specifications. Fairchild Semiconductor reserves the right to make changes at any time without notice to improve design.
Obsolete	Not In Production	This datasheet contains specifications on a product that has been discontinued by Fairchild semiconductor. The datasheet is printed for reference information only.

Rev. I20

Mouser Electronics

Authorized Distributor

Click to View Pricing, Inventory, Delivery & Lifecycle Information:

Fairchild Semiconductor:

[CNY171TVM](#) [CNY173SR2VM](#) [CNY173SR2M](#) [CNY173VM](#) [MOC81073S](#) [MOC8107SD](#) [CNY171SM](#) [CNY171VM](#)
[CNY173TVM](#) [MOC8107300W](#) [CNY171SR2M](#) [CNY173SM](#) [MOC81073SD](#) [MOC8107](#) [MOC8106SM](#) [MOC8107300](#)
[CNY171M](#) [CNY173M](#) [CNY171SVM](#) [MOC8107W](#) [MOC8107S](#) [CNY171SR2VM](#) [MOC8106SR2M](#) [CNY173SVM](#)
[MOC8107TVM](#) [MOC8106M](#) [CNY17F1TVM](#) [CNY17F4SR2VM](#) [CNY17F3TVM](#) [CNY174M](#) [CNY174SM](#)
[CNY174SR2M](#) [CNY174SR2VM](#) [CNY174SVM](#) [CNY174TVM](#) [CNY174VM](#) [CNY17F1M](#) [CNY17F1SM](#) [CNY17F1SR2M](#)
[CNY17F1SR2VM](#) [CNY17F1VM](#) [CNY17F2M](#) [CNY17F2SM](#) [CNY17F2SR2M](#) [CNY17F2SR2VM](#) [CNY17F2SVM](#)
[CNY17F2TVM](#) [CNY17F2VM](#) [CNY17F3M](#) [CNY17F3SM](#) [CNY17F3SR2M](#) [CNY17F3SR2VM](#) [CNY17F3VM](#)
[CNY17F4M](#) [CNY17F4SM](#) [CNY17F4SR2M](#) [CNY17F4SVM](#) [CNY17F4TVM](#) [CNY17F4VM](#) [MOC8106SR2VM](#)
[CNY17F1W](#) [MOC8108300W](#) [CNY172300_Q](#) [MOC8108SD](#) [CNY17F3W](#) [CNY1713SD](#) [MOC8106300W](#)
[CNY172TVM](#) [CNY1713S](#) [CNY172SR2M](#) [CNY17F43S](#) [CNY17F1](#) [CNY174S](#) [CNY171300W](#) [CNY174TM](#) [CNY172](#)
[MOC8103300W](#) [MOC8106SD](#) [MOC8102W](#) [CNY1723S](#) [CNY173TM](#) [CNY17F4_Q](#) [CNY17F2TM](#) [CNY1743SD](#)
[MOC8102S](#) [CNY172VM](#) [CNY17F3S](#) [CNY171FR2M](#) [MOC8106S](#) [CNY174FR2VM](#) [CNY174W](#) [MOC81013SD](#)
[CNY17F2](#) [CNY17F3SR2M_F132](#) [CNY173FVM](#) [CNY171_Q](#) [MOC8106W](#) [CNY1733SD](#) [MOC81053S](#)
[CNY17F1300W](#)