

5-channel BTL Driver for DVD player

AM5888S

The AM5888S is a five-channel BTL driver IC for driving the motors and actuators such as used in DVD player and consists of two independent precision voltage regulators with adjustable range from 1.5V to 4 V. It supports a variety of applications. Also, Pb free package is selectable (Please refer to Marking Identification).

● Applications

BTL driver for CD, CD-ROM and DVD.

● Features

- 1) Two channels are voltage-type BTL drivers for actuators of tracking and focus. Two channels are voltage-type BTL driver for sled and spindle motors. It is also built-in one channel bi-direction DC motor driver for tray.
- 2) Wide dynamic range [9.0V (*typ.*) when $V_{cc1}=V_{cc2}=12V$, at $R_L=20\Omega$ load].
- 3) Separating power of V_{cc1} and V_{cc2} is to improve power efficiency by a low supply voltage for tracking, focus, and spindle.
- 4) Level shift circuit built-in.
- 5) Thermal shut down circuit built-in.
- 6) Mute mode built-in.
- 7) **Dual actuator drivers:**
A general purpose input OP provides differential input for signal addition. The output structure is two power OPAMPS in bridge configuration.
- 8) **Sled motor driver:**
A general purpose input OP provides differential input for signal addition. The output structure is one power OPAMP in bridge configuration.
- 9) **Spindle driver:**
Single input linear BTL driver. The output structure are two power OPAMPS in bridge configuration.
- 10) **Tray in-out driver:**
The DC motor driver supports forward/reverse control for tray motor.
- 11) **2 Built-in regulator controllers**
Adjustable range 1.5V ~ 4V

● **Absolute maximum ratings (Ta=25°C)**

Parameter	Symbol	Limits	Unit
Supply voltage	Vcc1 Vcc2	13.5	V
Power dissipation	P _d	*1.7	W
Operate Temp range	T _{opr}	-35 ~ +85	°C
Storage Temp range	T _{stg}	**-.55 ~ +150	°C

*When mounted on a 70mm×70mm×1.6mm glass epoxy board.

*Reduced by 13.6mW for each increase in T_a of 1°C over 25°C.

**Should not exceed Pd or ASO and T_j=150°C values

● **Guaranteed operating conditions (Ta=25°C)**

Parameter	Symbol	Limits	Unit
Power supply voltage	Vcc1	4.3 ~ 13.2	V
	Vcc2	4.3 ~ Vcc1	V

● **Block diagram**

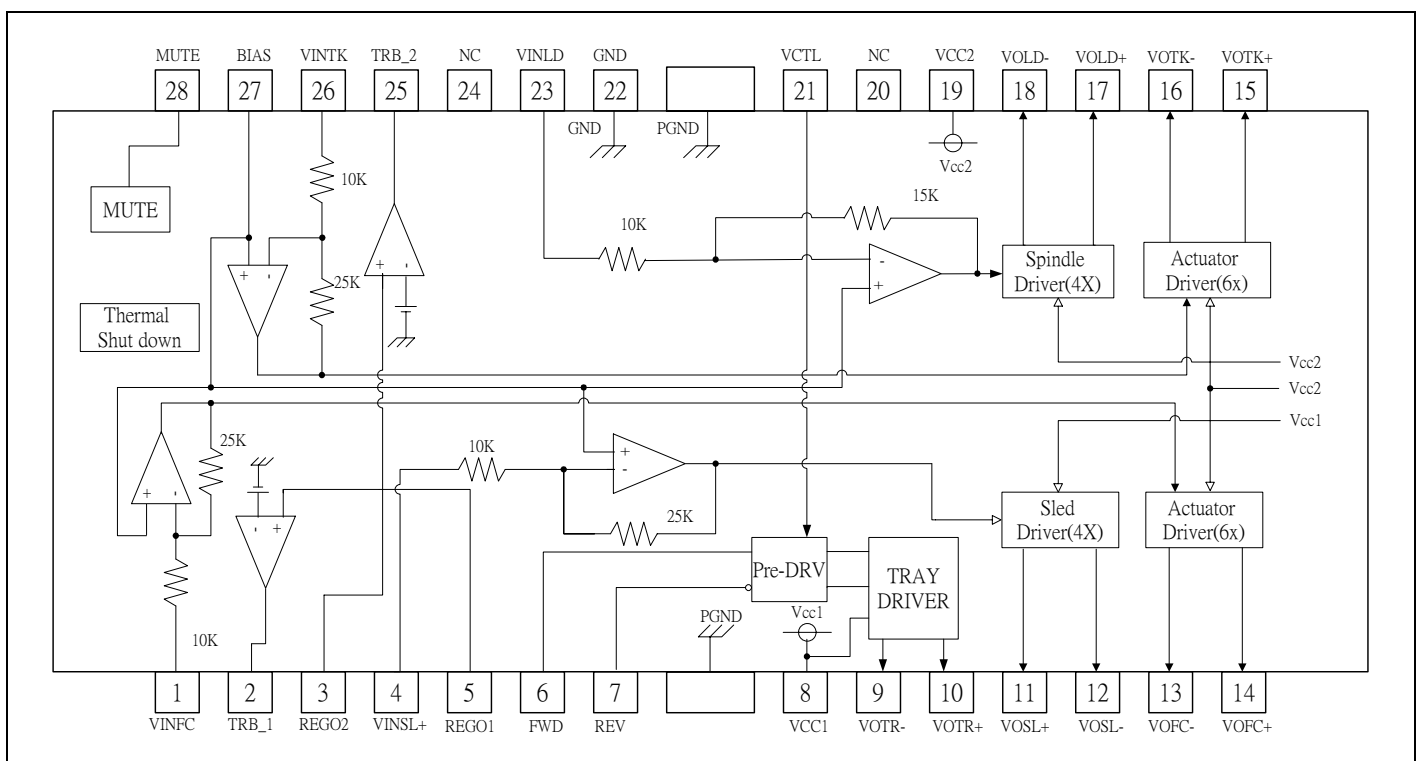

● Electrical characteristics

(Unless otherwise specified $T_a=25^{\circ}\text{C}$, $V_{cc1}=12\text{V}$, $V_{cc2}=5\text{V}$, $\text{BIAS}=2.5\text{V}$, $R_L=8\Omega/10\Omega/20\Omega/45\Omega$)

Parameter	Symbol	Limit			Unit	Conditions	P.S
		Min	Typ	Max			
Quiescent current	I_{cc}	-	30	-	mA		
Voltage for mute ON	V_{ston}	0	-	0.5	V		
Voltage for mute OFF	V_{stofd}	2.0	-	5	V		
<Actuator drivers>							
Output offset voltage	V_{oo}	-	-	± 50	mV		
Maximum output voltage	V_{om}	3.6	4.0	-	V	@10 Ω Load	
Voltage gain	G_v	21.5	23.5	25.5	dB	$V_{IN}=\text{BIAS}+0.2\text{Vpp ac @1KHz}$	
<Sled motor driver>							
Output offset voltage	V_{oofsl}	-	-	± 100	mV		
Maximum output voltage	V_{omsl}	7.5	9.0	-	V	@20 Ω Load	
Closed loop voltage gain	G_{vsl}	18	20	22	dB	$V_{IN}=\text{BIAS}+0.2\text{Vpp ac @1KHz}$	
<Spindle motor driver>							
Output offset voltage	V_{oofld}	-	-	± 50	mV		
Maximum output voltage	V_{omax}	-	3.5	-	V	@8 Ω Load	
Voltage gain	G_{vld}	13.3	15.5	17.5	dB	$V_{IN}=\text{BIAS}+0.2\text{Vpp ac @1KHz}$	
Gain error by polarity	ΔG_{vld}	0	1	2	dB	$V_{IN}=\text{BIAS}+0.2\text{Vpp ac @1KHz}$	
<Tray motor driver>							
Output saturation voltage 1	V_{SAT1}	0.7	1.1	1.5	V	Upper + Lower saturation, $I_L=200\text{mA}$	
Output saturation voltage between F&R	ΔV_{SAT1}	-	-	0.1	V	Output saturation voltage 1 between FWD and REV	
Output saturation voltage 2	V_{SAT2}	1.0	1.55	2.2	V	Upper + Lower saturation, $I_L=500\text{mA}$	
Output adjustable gain on "H" side voltage	V_{VtrH}	7.4	9.2	11	dB	$V_{CTL}=2\text{V}$	
<Tray motor driver input logic>							
High level input voltage	V_{IH}	1.5	-	V_{cc}	V		
Low level input voltage	V_{IL}	-0.3	-	0.5	V		
High level input current	I_{IH}	-	180	270	μA	$V_{FWD}=V_{REV}=5\text{V}$	
<Regulator> **							
Output voltage	V_{reg}	1.5		4.0		$I_L = 500\text{mA} ***$	
Output load differential	ΔV_{RL}	-50	0	50	mV	$I_L = 0\sim 500\text{mA}$	
Power supply voltage differential	ΔV_{VCC}	-25	0	25	mV	$(V_{cc}=4.5\sim 8\text{V}) I_L = 500\text{mA}$	

*This device is not designed for protection against radioactive rays.

** It is based on 8550C PNP application

*** It is based on 8550D

● Pin configuration

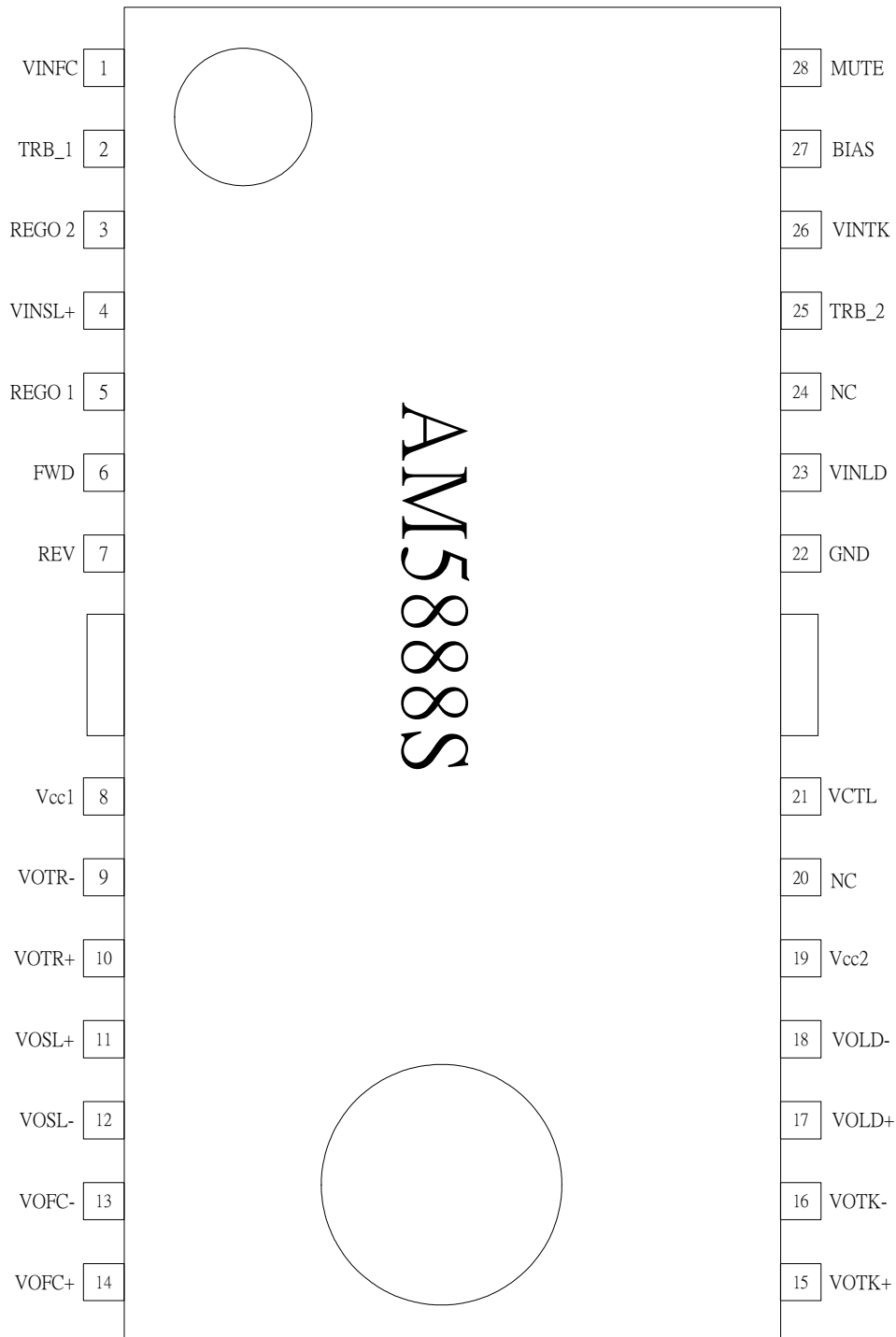

● **Pin description**

PIN No	Pin Name	Function
1	VINFC	Input for focus driver
2	TRB_1	Connect to external transistor base
3	REGO2	Regulator voltage output, connect to external transistor collector
4	VINSL+	Input for the sled driver
5	REGO1	Regulator voltage output, connect to external transistor collector
6	FWD	Tray driver forward input
7	REV	Tray driver reverse input
8	Vcc1	Vcc for pre-drive block and power block of sled and tray
9	VOTR-	Tray driver output (-)
10	VOTR+	Tray driver output (+)
11	VOSL+	Sled driver output (+)
12	VOSL-	Sled driver output (-)
13	VOFC-	Focus driver output (-)
14	VOFC+	Focus driver output (+)
15	VOTK+	Tracking driver output (+)
16	VOTK-	Tracking driver output (-)
17	VOLD+	Spindle driver output (+)
18	VOLD-	Spindle driver output (-)
19	Vcc2	Vcc for power block of spindle, tracking and focus
20	NC	No Connection
21	VCTL	Speed control input of tray driver
22	GND	Ground
23	VINLD	Input for spindle driver
24	NC	No Connection
25	TRB_2	Connect to external transistor base
26	VINTK	Input for tracking driver
27	BIAS	Input for reference voltage
28	MUTE	Input for mute control

Notes) Symbol of + and – (output of drivers) means polarity to input pin.
(For example, if voltage of pin1 is high, pin14 is high.)

● **Power dissipation curve :**

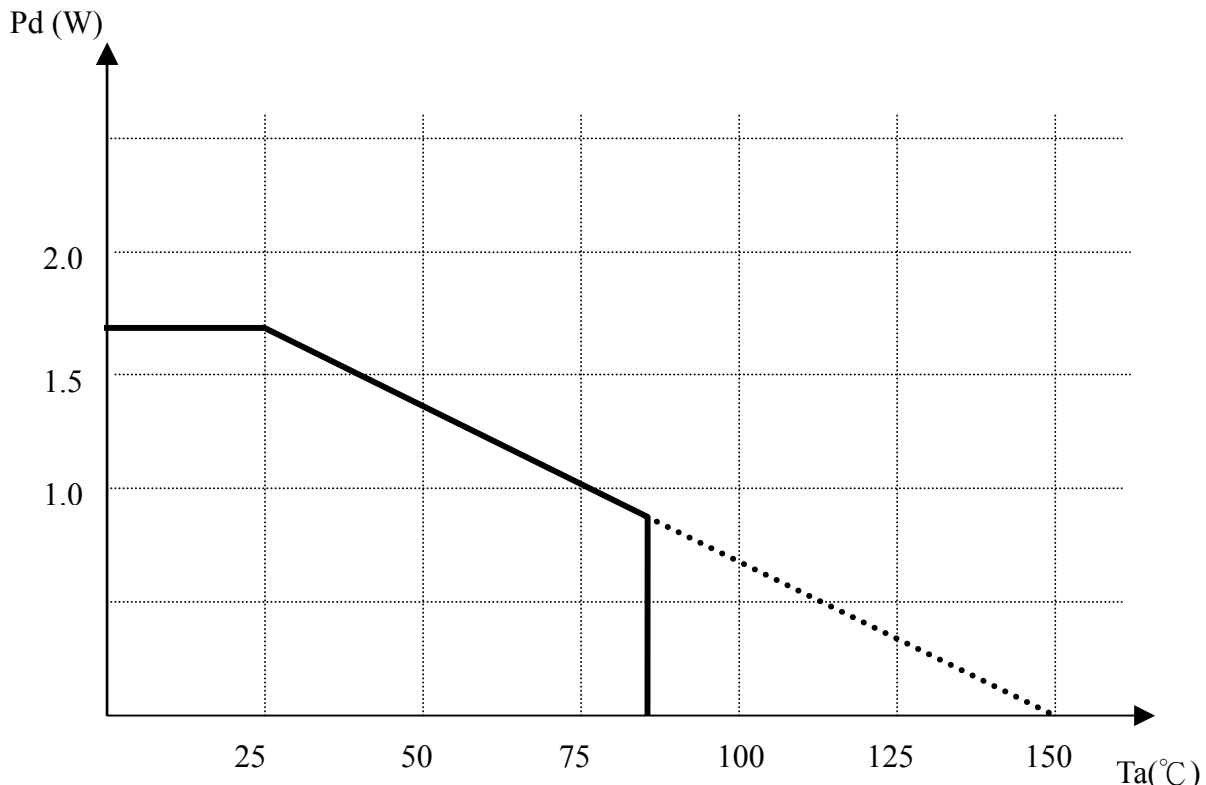

*70mm×70mm×1.6mm glass epoxy board.

*De-rating is done at 13.6mW/°C for operating above $T_a=25^\circ\text{C}$

● **Operation notes**

- 1) The built-in thermal shutdown circuit mutes the output current when the chip temperature reaches 175°C (typ.). The hysteresis is set to 25°C (typ.), so the circuit will start up again when the chip temperature falling to 150°C (typ.).
- 2) In case mute pin voltage is under 0.5V or NC, output current is muted (except for tray motor driver). Mute pin voltage should be more than 2.0V for normal application.
- 3) Bias pin (pin 27) should be pulled up to more than 1.2V. In case the bias pin voltage is pulled down below 0.9V (typ.), the output current is muted.
- 4) Insert the bypass capacitor (~ 0.1uF) between Vcc pin and GND pin as close as possible.
- 5) Heat dissipation fins are attached to the GND on the inside of the package. Make sure to connect them to the external GND.
- 6) NC pins (20, 24) are reserved for internal test. Please keep them floating.

7) Tray driver logic input:

FWD (pin6)	REV (pin7)	VOTR+ (pin10)	VOTR- (pin9)	Function
L	L	OPEN	OPEN	Open mode
L	H	L	H	Reverse mode
H	L	H	L	Forward mode
H	H	L	L	Brake mode

Input circuit of pin6 and pin7 is designed to avoid simultaneous activation of upper and lower output tr. ; however, in order to improve reliability, apply motor forward/reverse input once through open mode.

We recommend time period for open longer than 10msec.

“H” side Output voltage on output voltage (VOL+, VOL-) varies depending on output control terminal for tray (pin21). “H” side output voltage is set three times (9.2dB Typ.) VTCL(pin21). And, “L” side output voltage is equal to output saturation voltage.

● **Application circuit**

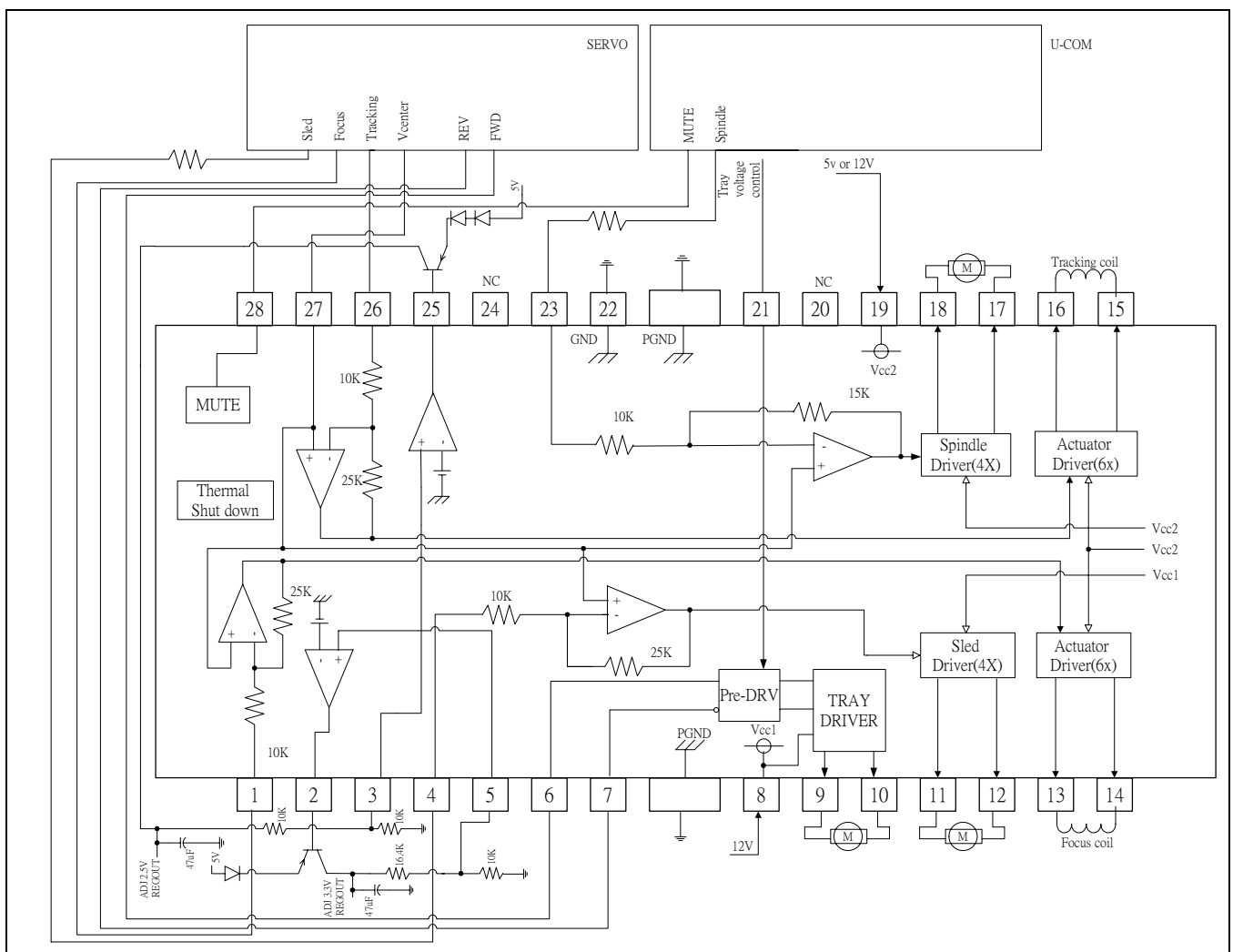

● Testing circuit

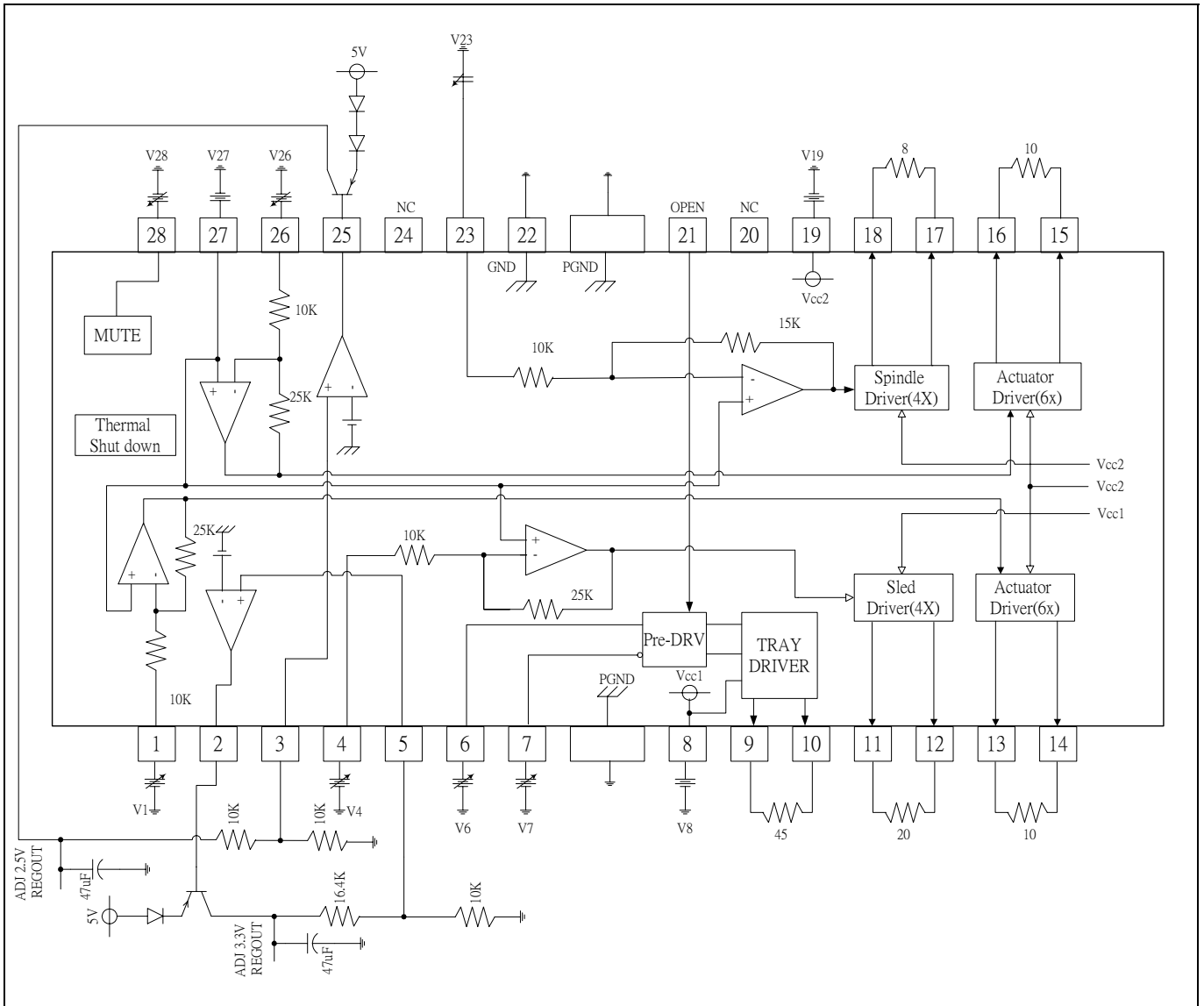

● Packaging outline

HSOP28

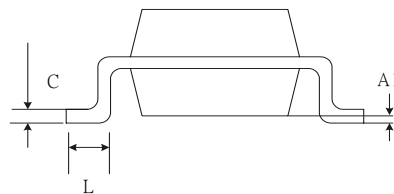
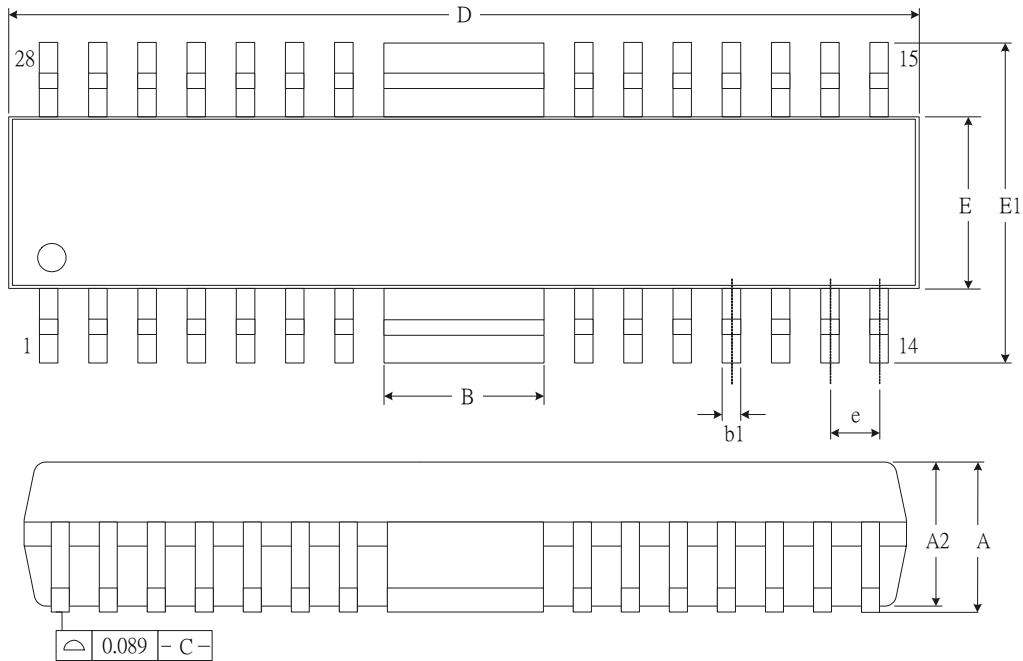

SYMBOL	MILLIMETERS		INCHES	
	Min.	Max.	Min.	Max.
A	-	2.75	-	0.108
A1	-	0.3	-	0.012
A2	-	2.45	-	0.096
B	4.95	5.35	0.195	0.211
b1	0.23	0.47	0.009	0.019
C	0.2	0.36	0.008	0.014
D	17.89	18.8	0.704	0.740
E	7.3	7.9	0.287	0.311
E1	9.6	10.65	0.378	0.419
e	0.8 (TYP)		0.031(TYP)	
L	0.3	-	0.012	-

● **Marking Identification**

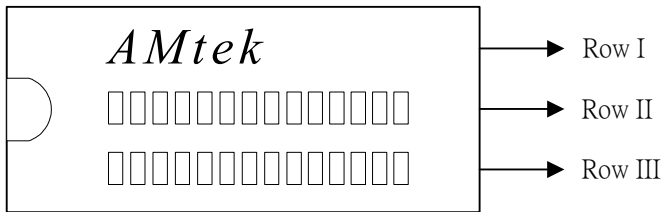

Row I
AMtek

Row II
Part number (Pb)
Part number L/F (Pb free)

Row III
Lot number