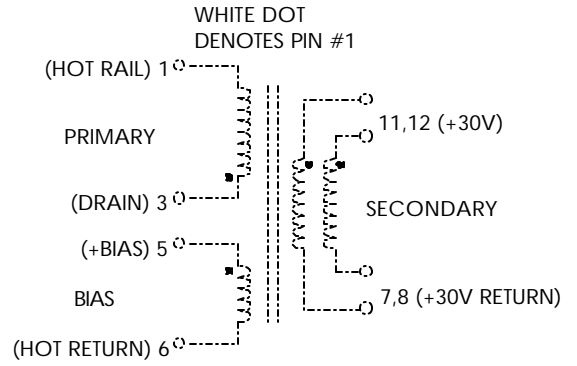

TABLE 1: ELECTRICAL SPECIFICATIONS AT 25 °C
 SWITCHING TRANSFORMER DESIGNED FOR USE WITH POWER INTEGRATIONS
 PWR-TOP227Y. REFER TO APPLICATION CIRCUITS OF FIGURE 3.

PARAMETER	SPEC LIMITS			UNITS
	MIN.	TYP.	MAX.	
PRIMARY INDUCTANCE (3-1) VOLTAGE = 0.250Vrms FREQUENCY = 100KHZ	675	750	825	μHY
TURN RATIO'S: SEC (11,12-7,8) : PRIMARY (3-1) BIAS (5-6) : PRIMARY (3-1)	-----	1:4.000 1:9.333	-----	± 4% ± 4%
PRILEAKAGE IND. (SEC SHORTED) VOLTAGE = 0.250Vrms FREQUENCY = 100KHZ	-----	8.5	12.0	μHY
HIPOT: 50/60Hz, 1 Minute Minimum PRIMARY TO SECONDARY BIAS TO SECONDARY	3750 3750	----- -----	----- -----	Vrms Vrms
FIGURE 3 CIRCUIT PARAMETERS: (1) AC LINE VOLTAGE 47/400Hz OUTPUT VOLTAGE OUTPUT CURRENT CONTINUOUS OUTPUT CURRENT PEAK LINE REGULATION (85 TO 265Vac) LOAD REGULATION 10-100% RIPPLE	85 ----- 0.10 ----- ----- ----- ----- -----	----- 30.0 ----- ----- 0.20 0.20 50.0	265 ----- 3.00 3.20 ----- ----- -----	Vac Vdc Amps Amps ±% ±% ±mV

(1) REFER TO APPLICATION CIRCUIT OF FIGURE 3A.
 FOR 28.0V @ 4.0A, VOLTAGE DOUBLER VERSION REFER TO FIGURE 3B.

FIGURE 1: SCHEMATIC DIAGRAM



SECONDARY PINS #12 & 11, #8 & 7 MUST
 BE RESPECTIVELY CONNECTED TOGETHER
 FOR PROPER OPERATION.
 I.E. CONNECTED AS ONE PARALLEL WINDING.

NOTE1:
REINFORCED INSULATION SYSTEM, UL1950, IEC950, CSA-950:
 A) ALL MATERIALS MEET "UL", "CSA" & "IEC" REQUIREMENTS
 B) TRIPLE BASIC INSULATED SECONDARY.
 C) DESIGNED TO MEET >6.2mm CREEPAGE REQUIREMENTS.
 D) VARNISH FINISHED ASSEMBLY.
 E) UL1950 & CSA-950 CERTIFIED: FILE #E162344.
 F) UL CLASS (B) 130 INSULATION SYSTEM PM130-R1,
 PM130-H1, PM130-H1A (UL FILE #E177139) OR ANY UL
 AUTHORIZED CLASS (B) INSULATION SYSTEM.

FIGURE 2: PHYSICAL DIMENSIONS mm (INCHES)

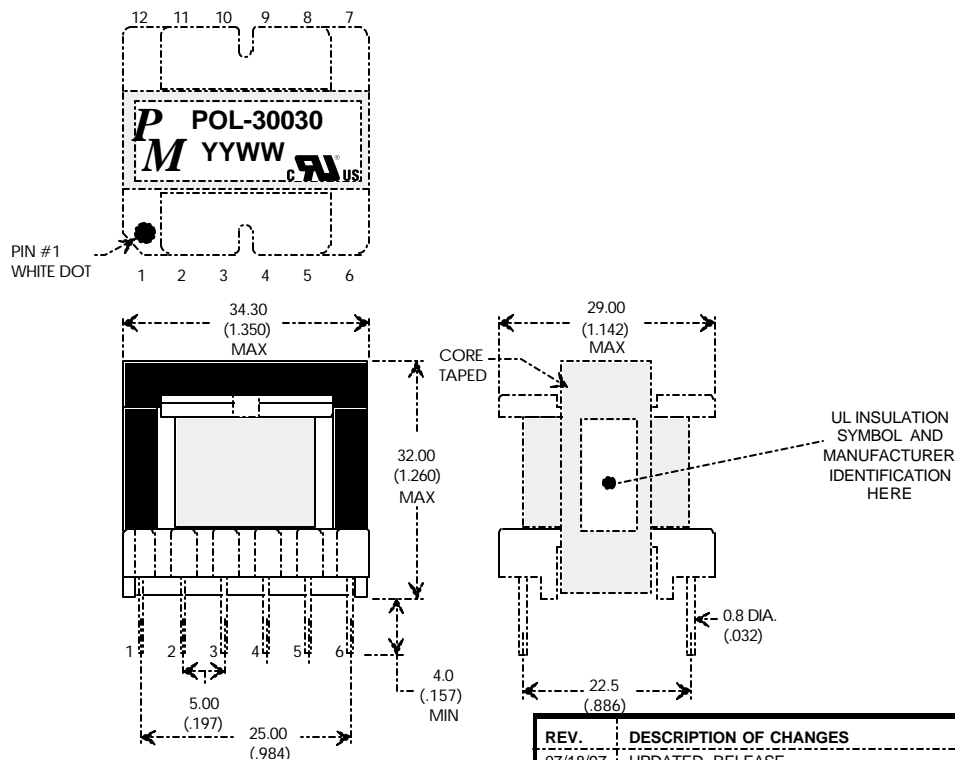

EI33/29/13 -OR- EI33, 12-PIN VERTICAL BOBBIN



UNLESS OTHERWISE SPECIFIED
 DIMENSIONS ARE IN MM
 DIMENSIONAL TOLERANCES ARE:
 DECIMALS ANGLES
 .X ± .25 ±0° 30'
 .XX ± .15
 DO NOT SCALE DRAWING

REV.	DESCRIPTION OF CHANGES	BY	TO
07/18/97	UPDATED RELEASE		
05/20/98	ADDED SECOND APPLICATION CIRCUIT FIG. 3B & UL/CSA APPROVALS		
03/05/99	UPDATED TO UL CLASS (B) INSULATION SYSTEM		MD
04/20/99	CHANGED LEAKAGE INDUCTANCE FROM 16.0 MAX TO 12.0 MAX		MD
01/06/04	CORRECT PART NUMBER ON PAGE 2 & 3		PP

FLYBACK TRANSFORMER CONTROL DRAWING	
PREMIER P/N: POL-30030	REVISION: 01/06/04
DRAWN BY: PETER PHAM	REF: PWR-TOP227Y
SCALE: NONE	SHEET: 1 OF 7

APPLICATION NOTES

Premier Magnetics POL-30030 Switch Mode Transformer was designed for use with Power Integrations, Inc. PWR-TOP204YA three terminal off-line PWM switching regulator in the Flyback Buck-Boost circuit configuration. This conversion topology can provide isolated multiple outputs with efficiencies up to 90%. Premier's POL-30030 transformer has been optimized to provide maximum power throughput.

The PWR-TOPXXX series from Power Integrations, Inc. are self contained 100KHz three terminal voltage controlled PWM switching regulators. This series contains all necessary functions for an off-line switched mode control DC power source. These switching regulators provide a very simple solution to off-line designs. The inductors and transformer used with the PWR-TOPXXX are critical to the performance of the circuit. They define the overall efficiency, output power and overall physical size.

Below is a universal input high precision 90 watt application circuit utilizing Power Integrations PWR-TOP227 switching regulator in the flyback buck-boost configuration. The component values listed are intended for reference purposes only. Properly sized heat sinks for the TOP227Y & D3 as well as proper thermal management & board layout are critical requirements for efficient and reliable operation.

FIGURE 3: TYPICAL APPLICATION CIRCUIT

PREMIER MAGNETICS PART NUMBERS:

(REQUEST DATA SHEETS BY PART#)

L1 = PMCE-0160 16mHy 1.5A EMI/RFI CMC

T1 = POL-30030 MAIN SWITCHING TRANSFORMER

L2 = VTP-01002 8uHy@4.0A(10uHy@2.0A) INDUCTOR

ALUMINUM ELECTROLYTIC FILTER CAPACITOR RATINGS:

C1: $\geq 400V$, Ripple Rated $\geq 790mA$ @ 120Hz @ Max. Operating Temp.
(Nichicon P/N LLQ2G471MHSC, 85C)

C2, C3: $\geq 50V$, IN PARALLEL Ripple Rated $\geq 3500mA$ @ 100KHz @ Max. Op. Temp.
(Panasonic P/N EEUFA1H102L, 105C)

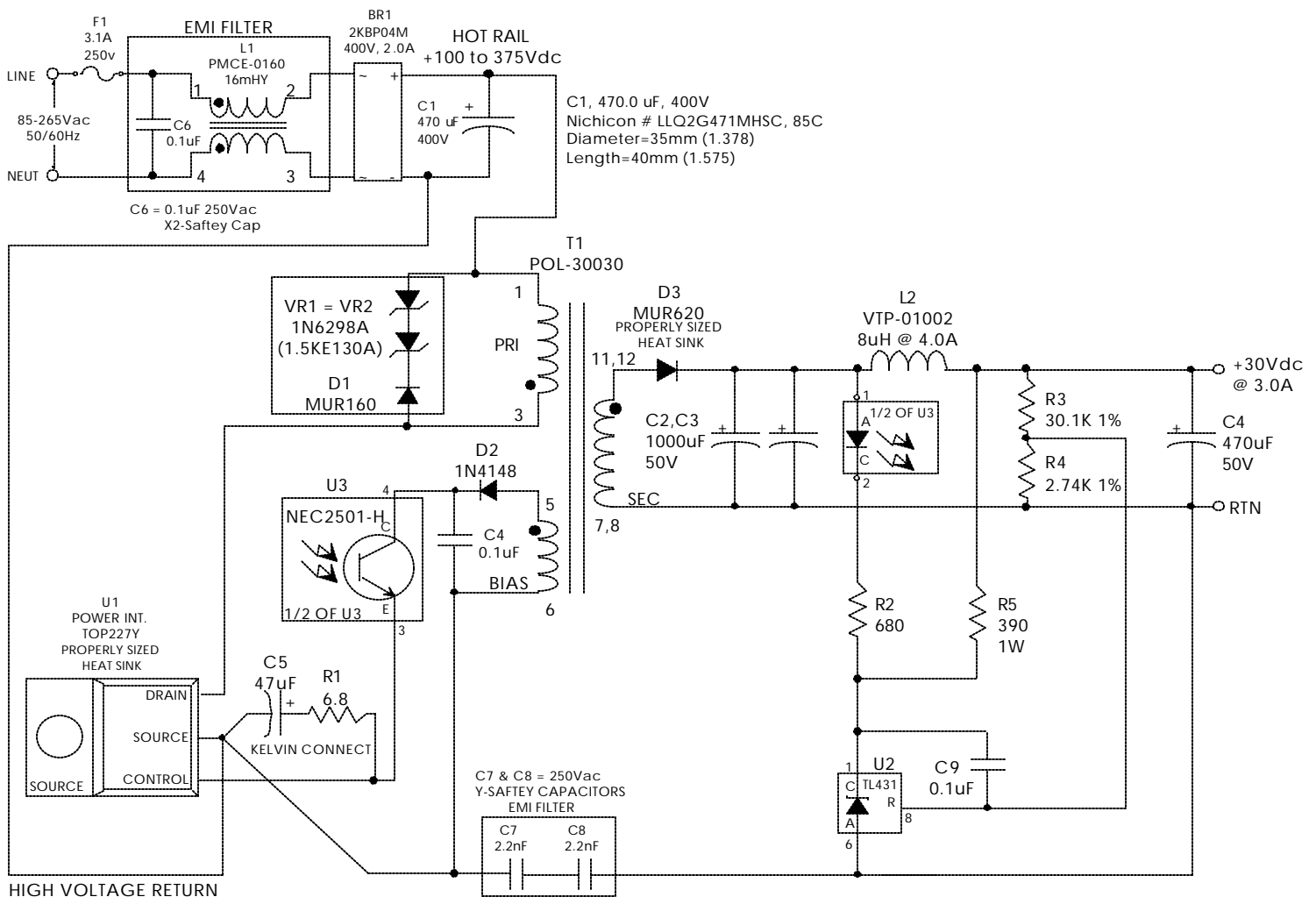

UNLESS OTHERWISE SPECIFIED
DIMENSIONS ARE IN MM
DIMENSIONAL TOLERANCES ARE:
DECIMALS ANGLES
.X $\pm .25$ $\pm 0^\circ 30'$
.XX $\pm .15$
DO NOT SCALE DRAWING

FLYBACK TRANSFORMER CONTROL DRAWING	
PREMIER P/N: POL-30030	REVISION: 01/06/04
DRAWN BY: PETER PHAM	REF: PWR-TOP227Y
SCALE: NONE	SHEET: 2 OF 7

APPLICATION NOTES FOR 28.0V @ 4.00A

Below is voltage doubler input high precision 112 watt application circuit utilizing Power Integrations TOP227Y switching regulator in the flyback buck-boost configuration. The component values listed are intended for reference purposes only. Properly sized heat sinks for the TOP227 & D3 as well as proper thermal management of the clamp network are critical requirements for efficient and reliable operation.

PARAMETER	SPEC LIMITS			UNITS
	MIN.	TYP.	MAX.	
FIGURE 3B CIRCUIT PARAMETERS:				
OUTPUT VOLTAGE		28.0		Vdc
OUTPUT CURRENT CONTINUOUS	0.50	-----	4.00	Amps
OUTPUT CURRENT PEAK	-----	-----	4.20	Amps
LINE REGULATION (85 TO 132Vac)	-----	0.20	-----	±%
LOAD REGULATION 10-100%	-----	0.30	-----	±%
RIPPLE	-----	50.0	-----	±mV

FIGURE 3B: TYPICAL APPLICATION CIRCUIT

PREMIER MAGNETICS PART NUMBERS:
(REQUEST DATA SHEETS BY PART#)

- L1 = PMCE-0160 16mHy 1.5A EMI/RFI CMC
- T1 = POL-30030 MAIN SWITCHING TRANSFORMER
- L2 = VTP-01005 10uHy@5.0A INDUCTOR

ALUMINUM ELECTROLYTIC FILTER CAPACITOR RATINGS:

- C1: ≥ 400V, Ripple Rated ≥ 740mA @ 120Hz @ Max. Operating Temp. (Nichicon P/N LLQ2G471MHSC, 85C)
- C2, C3: ≥ 50V, IN PARALLEL Ripple Rated ≥ 3000mA @ 100KHz @ Max. Op. Temp. (Panasonic P/N EEUFA1H102L, 105C)

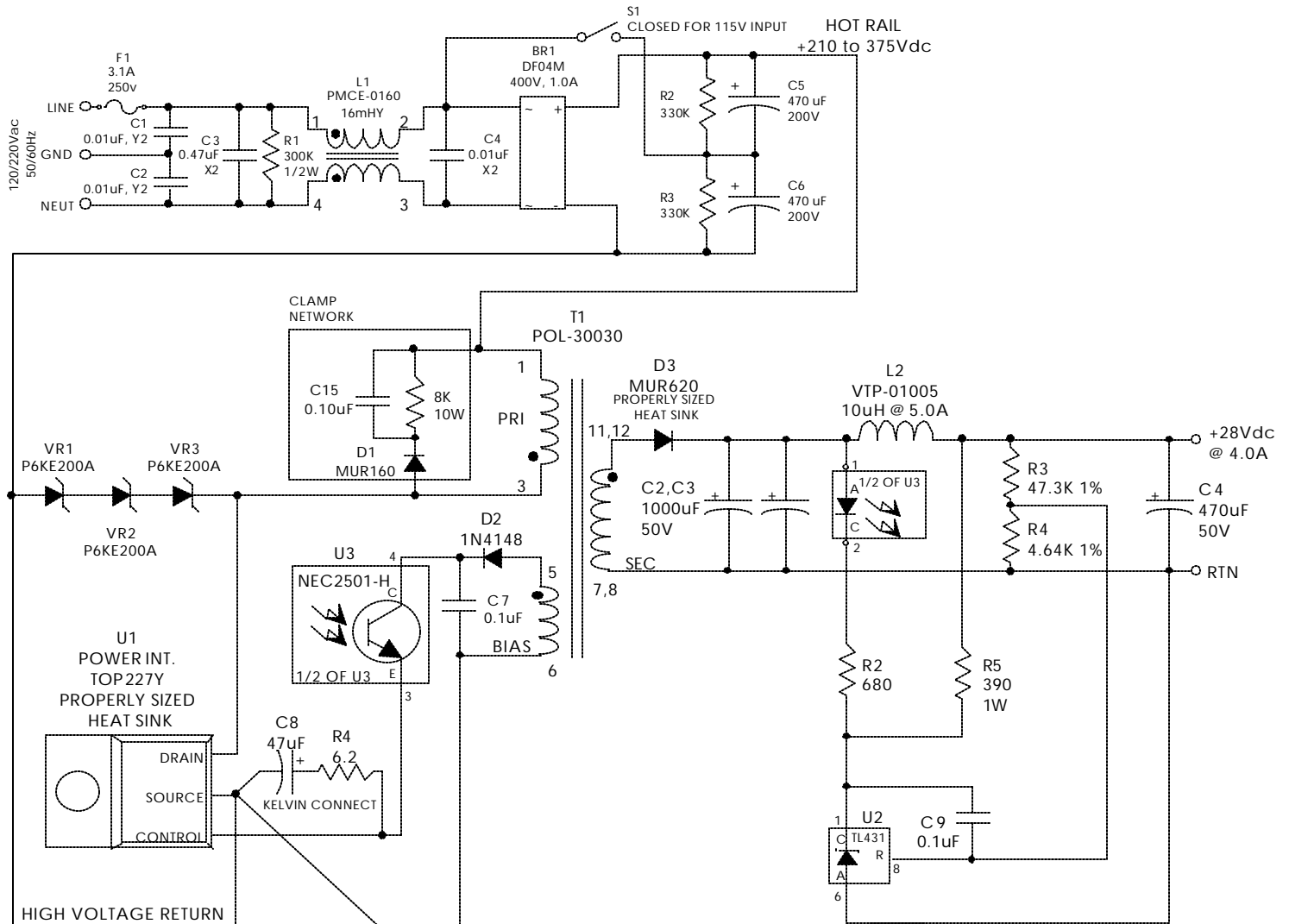

UNLESS OTHERWISE SPECIFIED
DIMENSIONS ARE IN MM
DIMENSIONAL TOLERANCES ARE:
DECIMALS ANGLES
.X ± .25 ±0° 30'
.XX ± .15
DO NOT SCALE DRAWING

FLYBACK TRANSFORMER CONTROL DRAWING	
PREMIER P/N: POL-30030	REVISION: 01/06/04
DRAWN BY: PETER PHAM	REF: PWR-TOP227Y
SCALE: NONE	SHEET: 3 OF 7